

NATURAL RESOURCE MANAGEMENT – NATURAL WEALTH ACCOUNTING*

GOVERNANCE AND ECONOMIC ACCOUNTING ISSUES IN THE MAURITIAN WATER SECTOR: TOWARD SUSTAINABLE MANAGEMENT OF A NATURAL RESOURCE

Peeroo, A.** , and Sultan, R.***

JEL Classification: H11; H54; L95; L98; Q25; Q56; R22

Keywords: water accounting; water supply and demand, economic value of water; sustainability; micro-institutions; water sector governance; water sector reform; decentralization

*“Natural Resource Management – Natural Wealth Accounting” is a capacity building program launched by the Global Development Network (GDN) in 2014 to help three ecologically fragile countries—Madagascar, Mauritius and Morocco—to understand the interactions between natural resources and socio-economic activities. The program is supported by the French Ministry of Foreign Affairs and International Development and the French Agency for Development (AFD).

** Chief Consultant (InfraGovernance Consulting) and Senior Research Fellow at Delft University of Technology. Contact: ap@infragovernance.com

***Senior Lecturer at the University of Mauritius, Department of Economics and Statistics. Contact: r.sultan@uom.ac.mu

Acknowledgments

We are grateful to the Global Development Network for its financial support and expertise, especially to Pierre Bertrand, Mansoor Ali Sait and Yashika Kanojia, who have accompanied this project all along. We extend our thanks to Prof. Bernard Barraqué, our scientific advisor. His comments and suggestions have always been helpful and extremely valuable as have been the numerous examples he has provided through his expertise and field experience. We would also like to thank the participants of the three GDN workshops for their input, and especially Jean-Louis Weber and Dr. Yann Laurans whose comments were very insightful and helped a lot in the early stages of the project. A special thanks and recognition goes to Ricardo Martinez-Lagunes for his valuable advice and for sharing his previous work on water accounts in Mauritius. In addition, we would like to thank Anand Sookun, our project assistant, who provided valuable input to the water accounts and all the statistics. Furthermore, our thanks go to the Charles Telfair Institute and its team, especially Vikash Rowtho, for hosting and organizing our workshop on water sector governance and the subsequent dissemination workshop. We would like to thank our student helpers: Suneil Boojhawon who did the layout for our policy briefs and Remena Mootien and Hanan Peerun who assisted with the dissemination workshop. Finally, we would like to thank David McDevitt who has done a great job editing our work.

Research discussed in this publication has been supported by the Global Development Network (GDN). The views expressed in this report are not necessarily those of GDN.

Table of Contents

List of Tables	5
List of Figures	6
List of Abbreviations	7
Abstract.....	8
Chapter 1: Introduction	8
1.1 Water Situation in Mauritius	9
1.2 Sustainability and Water Sector Governance	10
1.3 The Case for Water Accounts to Improve Decision Making and Governance	11
1.4 Objectives of the Study.....	11
1.5 Roadmap	12
References	14

SECTION 1: WATER ACCOUNTS, TRENDS IN WATER USE, AND ECONOMIC VALUE OF WATER IN MAURITIUS

15

Chapter 2: Water Accounting in Mauritius.....	16
Introduction.....	16
2.1 Water Accounting Systems: A Brief Review of the Literature.....	17
2.2 Water Accounting: Conceptual Framework	18
2.3 Water Accounts for Mauritius: Empirical Evidence.....	21
2.4 Water Asset Accounts.....	23
2.5 Water Balance.....	23
2.7 Total Water Abstraction: Sources and Users.....	27
2.8 Water Abstracted by the Water Supply Industry	28
2.9 Physical Flow Account of Water: Supply and Use Table.....	31
2.10 Water Abstraction at Regional and Seasonal Levels	35
2.11 Seasonal Water Accounts	37
References	42

Chapter 3: Trends in Water Use, Economic Value of Water, and a Scenario-based Analysis of Water Demand and Supply for 2030	44
Introduction.....	44
3.1 Water as an Economic Good.....	45
3.2 Water Utilization in Mauritius	46
3.3 Modeling Residential Water Consumption.....	48
3.4 Modeling the Demand for the non-Residential Sector: Marginal Productivity of Water	52
3.5 Scenario-based Analysis of Water Use and Water Abstraction.....	55
3.6 Water Abstraction Under Climate Change Scenarios.....	59
3.7. Behavior of Households Toward Water Shortages: Evidence From the Water Use Survey	61
Conclusion	64
References	65

SECTION TWO: WATER GOVERNANCE 67

Chapter 4: The Institutional Setting of Mauritian Water Sector Governance: What Place for Sustainability? 68

- Introduction..... 68
- 4.1 The Nature of Water Sector Governance 69
- 4.2 A Framework for the Analysis of Water Sector Governance..... 72
- 4.3 Mauritian Actors for Water Sector Governance and Their Sustainability Considerations..... 73
- 4.4 The Micro-institutional Set-up for Mauritian Water Sector Governance 82
- 4.5 Conclusion..... 86
- References..... 88

Chapter 5: Governance Issues in the Mauritian Water Sector Impeding Sustainability..... 91

- Introduction..... 91
- 5.1 Data..... 92
- 5.2 Governance Issues in the Mauritian Water Sector..... 93
- 5.3 Findings from the Analysis of Water Governance in Mauritius..... 98
- 5.4 Quo Vadis? 100
- References..... 102

SECTION THREE: POLICY IMPLICATIONS.....104

Chapter 6: Summary of Key Findings and Policy Recommendations 105

- Introduction..... 105
- 6.1 Water Accounts..... 105
- 6.2 Price, Income and Output Elasticity of Water 106
- 6.3 Household Survey on Water Use 106
- 6.4 Economic Value of Water 107
- 6.5 Forecast of Demand for Water and Climate Change Scenarios 107
- 6.6 Ensuring the Sustainable Supply of Water: Policy Implications 108
- 6.7 The Institutional Setting of Water Sector Governance 109
- 6.8 Water Sector Governance and (the Lack of) Sustainability..... 110
- 6.9 Policy Recommendations to Improve Water Sector Governance..... 111
- References..... 114

Annexes..... 115

- Annex A: Water Legislation in Mauritius..... 115
- Annex B: Water Governance Survey 124

List of Tables

Table 1: Basic Statistics for Mauritius for 2013.....	22
Table 2: Water Balance, 2009 to 2013 (million m ³)	24
Table 3: Water Balance in Mauritius, 2013 (million m ³).....	26
Table 4: Sources of Total Water Abstraction, 2008-2013 (million m ³)	27
Table 5: Water Abstraction Account, 2013	28
Table 6: Storage Capacity of Reservoirs in Mauritius	28
Table 7: Water Sources by Regions.....	29
Table 8: Minimum and Maximum Water Levels in Mauritius	30
Table 9: Water Abstraction by Water Supply Industry, 2003-2013 (million m ³)	30
Table 10: Water Account for the Water Supply Industry, 2013 (million m ³).....	31
Table 11: Supply Table for Water, 2013.....	32
Table 12: Use Table for Water, 2013	34
Table 13: Estimates of Water Requirements and Water Production on a Monthly Basis.....	35
Table 14: Seasonal Water Balance, 2013 (million m ³)	37
Table 15: Total Water Abstraction on Seasonal Basis, 2013 (million m ³).....	38
Table 16: Water Abstraction by Water Supply Industry on a Seasonal Basis, 2013 (million m ³)	38
Table 17: Supply and Use Table for Summer Season, 2013.....	39
Table 18: Supply and Use Table for Winter Season, 2013	40
Table 19: Water Consumption in Mauritius, 2013.....	47
Table 20: Domestic Monthly Tarrif for Potable Water, 2013	48
Table 21: Non-Domestic Monthly Tarrifs for Potable Water, 2014.....	48
Table 22: Unit Root Test of Variables.....	50
Table 23: Results for Demand for Water for Residential Purposes	51
Table 24: Long-run Demand Function for Water in Mauritius	51
Table 25: Regression Analysis of the Marginal Value of Water	54
Table 26: Trans-log Production Function	55
Table 27: Error Correction Model for Domestic Water Consumption.....	56
Table 28: Error Correction Mode for non-Domestic Water Consumption	57
Table 29: Residential and non-Residential Demand for Water in 2030	58
Table 30: Climate Change Scenarios for Rainfall by 2030 (A2, A1B and B1).....	60
Table 31: Indicators on Water from the Survey.....	62
Table 32: Ratio of Water Bill to Monthly Household Income	62
Table 33: Relationship between Share of Water Bill, Household Income and Household Size.....	63
Table 34: Logit Regression – Water Tank and Household Income	64
Table 35: Micro-Institutional Setting for Water Sector Governance in Mauritius	83

List of Figures

- Figure 1: Physical Water Flows within the Economy 20
- Figure 2: Total Rainfall in Mauritius, 2000 - 2013 (million m³) 24
- Figure 3. Distribution of rainfall in Mauritius in 2013..... 25
- Figure 4: Water Abstraction in Mauritius, 2000 to 2012 (million m³) 27
- Figure 5: Production of Potable Water Versus Water Demand, Northern Region..... 36
- Figure 6: Production of Potable Water Versus Water Demand, Southern Region..... 36
- Figure 7: Production of Potable Water Versus Water Demand, Central Region..... 37
- Figure 8: Demand for Water Consumption in the Residential Sector 50
- Figure 9: Consumer Surplus in Mauritius..... 52
- Figure 10: Forecast of Demand for Residential Water, 2016-2030 57
- Figure 11: Forecast of Demand in the non-Residential and Government Sectors, 2015-2030..... 58
- Figure 12: Aggregate Demand for Water in 2030 Under Different Economic Growth Scenarios 59
- Figure 13: Total Water Production Under Climate Change Scenarios in 2030 (millions m³) .. 60
- Figure 14: Water Shortages Under Different Climate Change and Economic Growth Scenarios (millions m³)..... 61
- Figure 15: Ratio of Water Bill to Monthly Household Income..... 63

List of Abbreviations

ARDL	Autoregressive Distribution Lag
CWA	Central Water Authority
ECM	Error Correction Model
GDN	Global Development Network
GPWA	General Purpose Water Accounting
IOC	Indian Ocean Commission
MEPU	Ministry of Energy and Public Utilities
MUR	Mauritius Rupee
PSUT	Physical Supply and Use Table
SEEA-Water	System of Environmental-Economic Accounting for Water
WFA	Water Footprint Accounting
WMA	Wastewater Management Authority
WRU	Water Resources Unit

Abstract

Mauritius faces a problem of water shortages, especially at the end of the winter season, which is revealed by seasonal water accounts. A household survey shows that 43% of households adapt to those shortages using water tanks and pumps. The study forecasts an increase in water demand of up to 51% by 2030 leading to a water shortage of up to 52 million m³ taking the effects of climate change into account. After analyzing different options, it seems that improvements in the water sector necessitates restructuring tariffs in different sectors with new roles of institutions in raising revenues. Current water sector governance, however, seems ineffective to solve these issues. The micro-institutional setting according to the distribution of tasks for each of the main transactions reveals a multitude of water actors at the national level. Responses from these water actors collected for this study point to a certain number of challenges putting sustainability at stake, including a lack of political commitment and discontinuity of reforms. These issues seem to be aggravated by a lack of independence of the main water agencies. The study concludes with policy recommendations to increase efficiency of the water sector.

Chapter 1: Introduction

Aleksandra Peeroo and Riad Sultan

1.1 Water Situation in Mauritius

Water is a vital natural resource for human activities and survival generally. While it may be abundant on a regional scale, only a small portion is typically usable, making it a *de facto* scarce resource. Of the total global water demand, 11 percent comes from households, 19 percent from industry (including energy production), with the bulk, 70 percent, coming from agriculture (Food and Agriculture Organization, 2012). Because of population growth and related increases in the demand for food and energy, it is expected that water demand will rise further in the future, putting more pressure on water resources.

These constraints on water resources are exacerbated by climate change. Among other impacts, rising sea levels risk contaminating freshwater supplies, and droughts and floods are becoming more frequent and more severe (International Environment Agency, 2012). Over-usage of water poses important threats. This is illustrated by the example of Mexico City, where the depletion of the underground aquifer has resulted in the city sinking by several meters, causing negative externalities like damage to buildings, roads, pipes and other infrastructure (Haggarty et al., 2002). In addition, competition for water provision between different consumer groups leads to conflict and may even cause social unrest (Ménard and Peeroo, 2011). Therefore, the sustainability of water is becoming a major policy issue for decision-makers.

In small island states, such as Mauritius, sustainability of the provision of water is an urgent issue for relevant stakeholders – including the various consumer groups, civil society groups, policymakers and the water supply industry. In 2013, Mauritius received 3,821 million cubic meters of rainfall of which 70 percent was available for exploitation through surface runoff (2,293 million m³) and groundwater (382 million m³). The remaining 30 percent (1,146 million m³) cannot be used for water production because it is lost to evapotranspiration. Furthermore, given the topography of Mauritius, a large proportion of the surface water runoff flows directly into the sea. For this reason, only 8 percent of available water was abstracted by the water supply industry for distribution to households, industry, government agencies and agriculture in 2013.

At first sight, it appears that there is no apparent water scarcity in Mauritius. However, two major issues pose a threat to the availability of drinking water. Firstly, there is a significant difference between the wet and dry seasons. Water reservoirs may be depleted by the end of the latter. Secondly, the production of drinking water by the national provider, the Central

Water Authority, involves a very high percentage of Non-Revenue Water,¹ amounting to around 55 percent (National Economic and Social Council, 2014, pp. 14 f.). Physical losses through leaky pipelines account for 35-40 percent of produced drinking water. Another 10-15 percent are commercial losses due to defective meters, illegal connections, etc. The remainder are explained by authorized unbilled consumption – for example, for fire fighting. Together, the amount of water lost corresponds to about four times the capacity of the largest reservoir on the island. This water wastage has been going on for decades. Given the high percentage of Non-Revenue Water, it is, therefore, not surprising that the supply of water scarcely meets the demand. As a consequence, some regions in Mauritius do not have access to potable water on a 24/7 basis.

1.2 Sustainability and Water Sector Governance

The current water situation in Mauritius urgently calls for sustainability considerations to be taken into account. Three facets of sustainability must be ensured with regard to water resources, and drinking water and wastewater services: economic, environmental and social. In this respect, effective water sector governance is vitally important for water (resource) management.² Problems in the governance of the water sector – understood as the system in place to oversee, plan, direct, monitor and enforce transactions between the various water uses – lead to dysfunctions that may become apparent in indicators of low performance, such as high leakage rates. In addition, sectoral characteristics, such as the natural decentralization of the water sector, usually influence the governance of the water sector (Peeroo, 2014, pp. 23 ff.). Decentralization is explained by two reasons. Firstly, water is physically heavy, one liter of water weighing one kilogram. This makes it difficult and costly to transport over long distances. As a consequence, water resources management is typically local or regional. Secondly, water utilities themselves are usually local. Therefore, local and regional actors play a natural role in the governance of the water sector (Ménard and Peeroo, 2011). A coherent system of water sector governance requires a clear distribution of tasks and responsibilities across various water actors. In order to direct policies toward the consideration of sustainability issues, the governance of the sector needs to be well understood so that institutional dysfunctions can be addressed (Peeroo, 2014, pp. 79, 158). The role of information is critical. Information must be relevant, standardized and coherent in order to provide a basis for good decision-making (*ibid.*, p. 166).

¹ Non-Revenue Water measures the percentage of water that has been produced but which has not generated any revenue.

² The Mauritian water sector involves water policy and politics with a specific set of actions and actors, separated from other public policies. Within the water sectors of high-income countries, two different sub-sectors can often be distinguished: one relating to water resources and the other to water services (both drinking and wastewater). In Mauritius, however, as in many developing countries, there are no such sub-sectors: the water sector consists only of one set of actors, although diversified and multiple. Formally, a specific Water Resource Unit exists, but it does not hold enough decision-making power to constitute a distinct sub-sector for water resources with independent actors and policies that are separated from the actors and policies concerning water services. We are grateful to Bernard Barraqué who pointed out this difference between the water sectors of developed and developing countries.

1.3 The Case for Water Accounts to Improve Decision Making and Governance

Information plays a crucial role in decision-making. In order to manage water sustainably, there is a need to organize information on water – including water storage, water distribution, and water use – in a relevant, standardized and coherent manner (Peeroo, 2014, p. 166). Natural resource accounting in the water sector provides information on the present state of water management in terms of its current use and economic contributions. It also assists in identifying future water uses and water management policies. Furthermore, it helps gain an understanding of how different policies will impact on water demand and informs on potential trade-offs. It also permits the conceptualization of the economic value of water. Consequently, the impact of droughts, climate change and any negative externalities on the water sector can be analyzed in terms of changes in the total volume, as well as changes in the natural wealth. A complete water account is useful to better manage water as a natural resource and to design instruments to ensure the sustainability of the water sector.

At the same time, water accounts may increase the informational basis for decision-making and, in turn, policymaking. However, the successful implementation of policies will depend on the governance and institutional setting. The economics of water indicates some ways to achieve efficient water management. Infrastructural weaknesses may require specific investment decisions, but institutional and governance issues may prevent a review of the tariff structure and thereby the necessary investments.

Therefore, an analysis of the governance issues in the Mauritian water sector is important in response to some of the questions that are raised from an analysis of supply and demand. A lack of effective water sector governance explains why it is so difficult to remedy a system which is not responding to the requirements of the population. The study of water governance issues also illustrates how (in)effective the system is in designing policies and strategies for the sector. In this respect, governance and economic accounting of water in Mauritius will play an important role in addressing the water crisis which the island is facing.

1.4 Objectives of the Study

The aim of the study is to conduct an assessment of governance issues in the context of a need for sustainable water services and to construct a water account system, together with an analysis of the economic contribution of water for the small island state of Mauritius.

The objectives of the study are:

- To make an assessment of the current water situation in Mauritius
- To conceptualize the physical use and supply of water in the Mauritian context and construct the economy-water linkages and a water account – based on the system of Environmental-Economic Water Accounting for Water (SEEA-Water)
- To study the demand for water in different sectors (agriculture, industry, energy, tourism and households) and its economic value to the economy

- To provide a scenario-based analysis of the impacts of climate change and changing trends of water use
- To draw a picture of the micro-institutional setting that governs the Mauritian water sector (actors with their respective responsibilities and levels of intervention)
- To critically analyse governance issues in the Mauritian water sector and its political economy
- To analyze the link between governance and sustainability considerations
- To design policy recommendations for sustainable water use and efficient water sector governance

1.5 Roadmap

Our study is structured in three sections. Section one (Chapters 1 and 2) are dedicated to questions related to the water accounts for Mauritius. The current trends of water demand are analyzed and data and information are collected to construct water accounts for the country. This offers insights on key indicators including price and income elasticities for the household sector, and output elasticity and marginal productivity of water in various economic sectors of Mauritius, which might prove helpful for policymaking. A survey on the water use by households has also been conducted, the results of which are provided in sub-section 3.7 of this study³. Furthermore, because sustainable water policies depend on future trends of water abstraction and water use, Chapter 3 forecasts water consumption for the non-residential and residential sectors in Mauritius for 2015 to 2030, taking into account different scenarios of how climate change and economic growth might impact on water demand.

Section two (Chapters 4 and 5) focuses on Mauritian water sector governance. Chapter 4 elaborates on the nature of water sector governance in general, and the issue of sustainability. It also provides a theoretical framework for the analysis of water sector governance, which is then applied to the case of Mauritius. Using an original dataset, the framework identifies the various water governance actors and their respective responsibilities. The objectives of Chapter 4 are thus twofold: firstly, to develop an institutional map for water sector governance in Mauritius and secondly, to analyse the extent to which the various water actors take sustainability considerations into account.

Chapter 5 is centered around a number of specific governance issues in the Mauritian water sector that have been highlighted by a survey that was conducted as part of the research. It appears that the main impediments to a more sustainable water sector are linked to weaknesses in governance – a lack of coordination of the multitude of water actors in an institutional environment with little transparency.

Chapter 6 sums up the major findings emanating from the previous chapters and provides policy implications for improving the sustainability of water supply in Mauritius. More specifically, it highlights some aspects of Mauritian water sector governance that endanger

³ The reader should contact Riad Sultan (r.sultan@uom.ac.mu) to obtain further information on this survey.

the sustainability of water and proposes a number of concrete policy measures that could be adopted to improve water sector governance.

References

- Food and Agriculture Organization (2012). United Nations Food and Agriculture Organization. Aquastat Database, www.fao.org/nr/water/aquastat/main/index.stm (30.09.2014).
- Haggarty, L., Brook, P., and Zuluaga, A. M. (2002). Water Sector Service Contracts in Mexico City, Mexico. In: Shirley, M. M. (ed.), *Thirsting for Efficiency: The Economics and Politics of Urban Water System Reform*, pp. 139-187. Amsterdam and others: The World Bank.
- International Environment Agency (2012). Water for Energy: Is Energy Becoming a Thirstier Resource? Excerpt from the World Energy Outlook 2012. Paris: International Energy Agency IEA online.
- Ménard, C. and Peeroo, A. (2011). Liberalization in the Water Sector: Three Leading Models. In: Finger, M. and Künneke, R. W. (eds.), *International Handbook of Network Industries: The Liberalization of Infrastructure*, pp. 310-327. Cheltenham and others: Edward Elgar Publishing.
- National Economic and Social Council. (2014). Management of Water Resources. NESC Report No. 28.
- Peeroo, A. (2014). *Decentralization and the Water Sector: Institutional Perspectives*. PhD, University of Paris 1 Panthéon-Sorbonne.

SECTION 1: WATER ACCOUNTS, TRENDS IN WATER USE, AND ECONOMIC VALUE OF WATER IN MAURITIUS

Chapter 2: Water Accounting in Mauritius

Riad Sultan

Introduction

The United Nations report, 'Water for a Sustainable World' (WWAP 2015), observes that over-abstraction of water is often the result of out-dated models of natural resource use. A sustainable water management system, therefore, calls for an efficient mechanism to organise information on water in the economy, in a relevant, reliable, understandable, comparable and timely manner (Molden, 1997; Molden and Sakthivadivel, 1999; Burrell et al., 2012; Chalmers et al., 2012). Water accounting has been a response to the lack of organised data in the water sector. It is a method of organising and presenting information relating to the physical volumes of water in the environment and economy, and the impacts of human activities on water resources (Vardon et al., 2007) and allows us to model the potential impacts of different policies in the water sector. It can be used to integrate the economic aspects of water supply and use. Moreover, managers in the water sector are facing greater demand for transparency with defined lines of responsibility and accountability. Therefore, a systematic means to record and report diverse data relating to water is becoming a necessity. Many countries are already preparing water accounts on a regular basis, while others have started their water accounts on a pilot basis (Lange and Hassan, 2006).

Following the pioneering work of the World Resources Institute (Repetto et al., 1989; Lange, 2007), water accounting is becoming increasingly popular in the analysis and design of sustainable development strategies. It aims at providing answers on how water is currently being used, the economic contribution of water use at a sectoral level, the opportunity cost of water use for each economic sector and whether the present use of water represents its best use (Lange, 1997). It may be further used to shed light on future water uses, with due consideration of the water demand by different sectors, and examine how policies may affect the demand for water to meet development objectives. Water accounting can help analyze economic trade-offs more easily and establish priorities (Lange, 1997).

This section of the study aims to construct water accounts for the small island economy of Mauritius, by analyzing the physical stock and flow of water, the utilization of water in different sectors and the supply of water from various sources (surface and ground). Water accounts are prepared for the year 2013, as well as on a seasonal basis to differentiate between summer and winter, using the System of Environmental-Economic Accounting for Water (SEEA-Water) guidelines.

This chapter is structured as follows: Section 2.1 provides a brief literature review on water accounting, followed by a description of the conceptual framework in Section 2.2. Reference is made to SEEA-Water, a document on the design of water accounts, published by the United Nations Statistics Division in 2007 (UN, 2012). Section 2.3 provides an overview of the water sector in Mauritius, together with water accounts for the country. Sections 2.4 to 2.11

provide the findings of the water accounts – explicitly classified as water asset accounts; water balance; total water abstraction; water abstracted by the water supply industry; physical flow account of water; water abstraction at regional and seasonal levels; and seasonal accounts.

2.1 Water Accounting Systems: A Brief Review of the Literature

It is increasingly recognized that for the effective management of a resource such as water, a systematic approach is needed to report information in a transparent manner. Water accounting enhances our understanding of the link between the water cycle and human activity, and provides a tool for improved management of water (Lange and Hassan, 2006). However, water accounting systems have different origins. According to Chalmers et al. (2012), water account systems can be regarded as a response to a social and institutional practice designed for intervening in the functioning of a sector. Over the years, several water accounting systems have been developed, such as the General Purpose Water Accounting (GPWA), the System of Environmental-Economic Accounting for Water (SEEA-Water), Water Footprint Accounting and a system implemented by the International Water Management Institute (IWMI WA).

The GPWA reports include a Statement of Physical Flows, a Statement of Water Assets and Water Liabilities, and a Statement of Changes in Water Assets and Water Liabilities (Burrell et al., 2012). The Statement of Physical Flows shows how holdings of water evolved during the reporting period. In the Statement of Water Assets and Water Liabilities, the assets component contains an overview of the water rights and other entitlements to water, while the liabilities component reports obligations to provide water or water rights (Chalmers et al., 2012). The Statement of Changes in Water Assets and Water Liabilities shows movements in water assets and water liabilities during the reporting period. According to Chalmers et al. (2012), the GPWA is more an assessment of accountability for water management and the consequent allocation of economic, environmental or social resources. It is primarily designed for stakeholders as a tool to facilitate decision-making on the allocation of resources.

The SEEA-Water was developed by the United Nations Statistics Division, in collaboration with the London Group on Environmental Accounting. This system is a conceptual framework for the organization of both physical and economic information related to water using concepts, definitions and classifications, consistent with those of the System of National Accounts 2008.⁴ The SEEA-Water is an extension of the United Nations System of Environmental-Economic Accounting, recording information on environmental and related socioeconomic indicators in a manner similar to the way in which many countries' national accounts record information about economic transactions. SEEA-Water accounting includes a physical supply and use table, showing flows of water from the environment to the economy and the movement of water within the economy. It also includes a water emissions

⁴ The System of National Accounts 2008 was adopted by the UN Statistical Division as the international standard for compilation of national accounts statistics and for the international reporting of comparable national accounting data.

account. Asset accounts record water stocks in physical terms (the volumes of water) and report their amounts at the beginning and end of a period, as well as the changes during a reporting period. According to Chalmers et al. (2012), SEEA-Water is based on the information needs of an assumed audience of policy analysts and informed researchers; as opposed to a general-purpose approach, which provides information for use by policymakers or stakeholders.

IWMI WA provides information on the supply and use of water and relates water use to the economy (Molden, 1997; Chalmers et al., 2012). It is a multi-scale method to account for the amount of water available, the amount of water used by various sectors and the value derived from water use. It is based on a water balance approach, which translates water balance components, and inflows and outflows into various water accounting categories such as net inflow, process consumption, non-process depletions, committed outflow and uncommitted outflow. One major difference between the IWMI WA and other accounting frameworks is the use of water consumption as opposed to water withdrawals. Accordingly, this approach helps to track water reuse as it accounts for consumed water rather than diverted flow to a particular domain. However, it does not show water withdrawals and the efficiency of water use (Karimi et al., 2012).

Many countries including China (Zhu et al., 2009), Australia (Chalmar et al., 2012; Turner et al., 2014), Botswana, Namibia and South Africa (Lange et al., 2006) have developed water accounts on a regular basis. Water accounts have been used to analyze issues such as poverty, economic growth and international trade, among others. Gao et al. (2013) use a water accounting model in Beijing to analyze development patterns and water consumption. Their study makes use of the input-output model. Biltonen and Dalton (2003), designed a framework which links water accounting to poverty. Lange and Hassan (2006), extend the water account systems prepared in Lange et al. (2006) to examine the link between international trade and water use in three countries: Botswana, Namibia and South Africa.

Physical and monetary accounts of water can be used to analyse a wide range of issues pertaining to water, including the constraints on water posed by the possible effects of climate change, the role of water pricing and conflict management among users. Consequently, they may also be used to analyze policies which maximize the wealth or economic efficiency of water as a natural resource, with due consideration of equity in, and sustainability of, the water sector.

2.2 Water Accounting: Conceptual Framework

Water accounting forms part of the National Resources Accounting detailed in the Integrated Environmental and Economic Accounting Handbook (UN, 2003). Since water requires specific treatment, the United Nations Statistical Division published the System of Economic-Environmental Accounting for Water (SEEA-Water) in 2007. The SEEA-Water

provides a framework to analyse the role of water in the economy through a system of satellite accounts linked to national accounts.⁵

Water accounting, according to SEEA-Water, is separated into water asset (or stock) accounts and water flow accounts (UN, 2012):

1. Asset accounts measure the stocks at the beginning and at the end of the accounting period and, record the changes in stocks that occur in between. There are two types of water assets, 'produced assets' and 'water resources':
 - a. Produced assets include the infrastructure to abstract, distribute, treat and discharge water.
 - b. Water resources describe the volume of water resources in the various asset categories at the beginning and the end of the accounting period and all the changes therein that are due to natural causes (precipitation, evapotranspiration, inflows, outflows) and human activities. In addition, quality accounts record stocks of water in terms of its quality.
2. Water flow accounts record the volume of water that passes from the environment into national economies. More specifically, they record the volume of water supplied by an economic agent either for its own use or for delivery to another use. It also records the volume used by both economic and domestic sectors (Arntzen et al., 2010).

Figure 1, reproduced from the SEEA-Water document (UN, 2012), describes physical water flows within the economy. Water flow is divided into three components: (i) the flow of water from the environment to the economy; (ii) flows of water within the economy and between economies; and (iii) flows from the economy to the environment.

⁵ As satellite accounts of the System of National Accounts, SEEA-Water is linked to a full range of economic activities with a comprehensive classification of environmental resources.

Figure 1: Physical Water Flows within the Economy

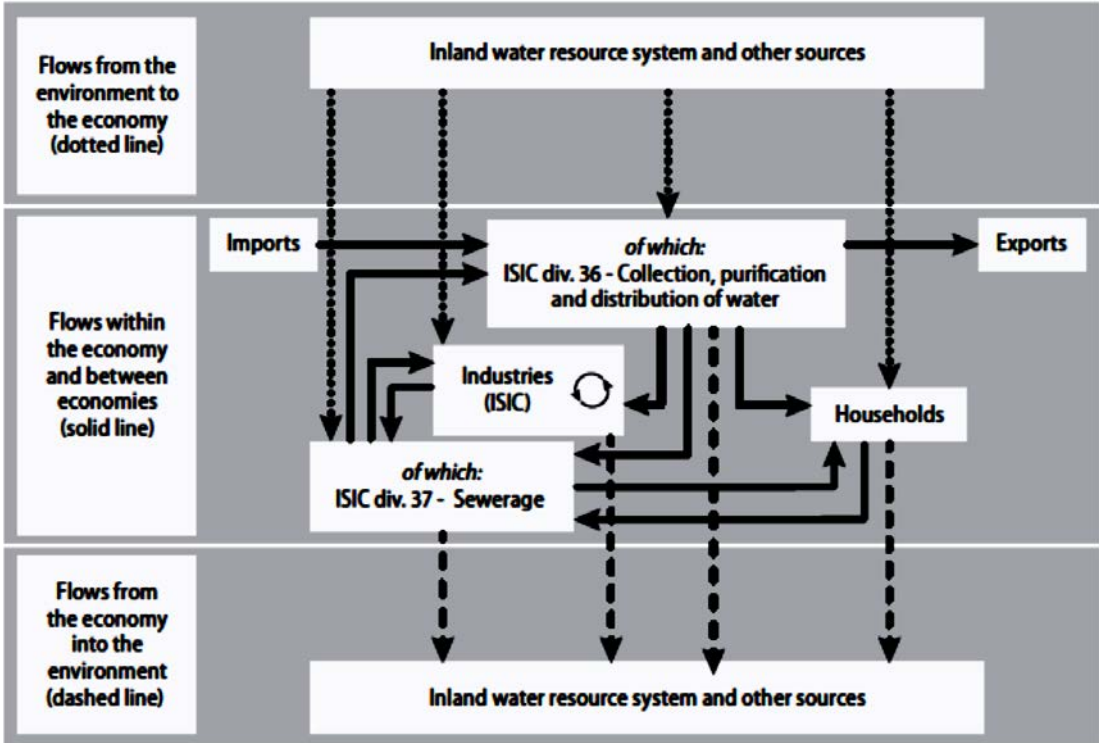

Source: SEEA-Water (UN, 2012)

Water supply and use tables are used to record components of the ‘inland water system’ – which includes surface water (rivers, lakes and artificial reservoirs), groundwater and soil water, within the territory of reference. All flows associated with the inland water system are recorded in the asset accounts for water resources, including flows to and from accessible seas and oceans.

According to SEEA-Water, physical supply and use tables can be compiled at various levels of detail, depending on the required policy and analytical focus, and data availability. A basic supply and use table for water is divided into five sections as follows:

1. Abstraction of water from the environment
2. Distribution and use of abstracted water across enterprises and households
3. Flows of wastewater and reused water (between households and enterprises)
4. Return flows of water to the environment
5. Evaporation, transpiration and water incorporated into products

The aim of physical flow accounting is to record the physical flows underpinning monetary transactions, primarily with respect to goods, and then to extend the supply and use tables to record physical flows from the environment to the economy (such as natural resources) and physical flows from the economy to the environment (such as emissions into air and water).

A specific terminology is used with regard to water accounts. The common definitions are as follows:

Available water: Available water is defined as the availability of internal renewable water resources. This gives an indication of the amount of water that is internally made available through precipitation (minus evapotranspiration, i.e. efficient precipitation). These resources are computed by adding up the volume of the average annual surface runoff and groundwater recharge occurring within a country's borders (UNSD, 2012). Thus the amount of **internal renewable water resources** is equivalent to the sum of the surface runoff and groundwater recharge.

Water abstraction refers to the amount of water which is used in economic sectors and the domestic sector. Abstraction must be distinguished from water which does not return to the environment, either because it has evaporated or because it has been incorporated in products or services.

Water use refers to the water received by economic and domestic sectors and which is returned to the environment after use with some alterations in its composition (e.g. waste water). Use describes the total amount of water withdrawn from its source to be used elsewhere.

Water consumption is the amount of water used which is not returned to the original water source after being withdrawn. Water consumption also includes water lost into the atmosphere through evaporation or transpiring from a product or plant if it is no longer available for reuse (World Resources Institute, 2013).

Outflow to sea: The difference between surface runoff and abstraction is the amount of water which runs to the sea. In other words, outflow to sea = surface runoff - abstraction + discharge of used water.

Distribution loss: This is the difference between production (supply) and use and consumption.

Utilization: Utilization is made up of consumptive use (irrigation, households and businesses) + non-consumptive use (incorporated into manufacturing products and hydropower consumption).

The first step in water accounting is to define the spatial domain (Molden, 1997; Karimov et al., 2012). Water stocks are classified by the SEEA-Water as surface water, groundwater and soil water. Surface water is further disaggregated and includes artificial reservoirs, lakes, rivers, snow, ice and glaciers. The net inflow is equal to the gross inflow minus the change in storage. The gross inflow comprises of efficient precipitation plus surface water and groundwater flows across the boundary. To avoid repetition, further explanation is provided in the section on water accounts for Mauritius.

2.3 Water Accounts for Mauritius: Empirical Evidence

The Republic of Mauritius is an island fringed by coral reefs. It has a surface area of 1,870 km² and a 322 km-long coastline. The island was formed as a result of a volcanic eruption

and, therefore, most of the rivers originate from the central plateau and flow toward the sea.

The population of Mauritius is currently 1.2 million and GDP is MUR 323.2 billion (USD 9.1 billion) – see Table 1. There are two seasons in Mauritius: winter, from May to October and summer, from November to April. The average annual precipitation over the island is 2,000 mm. The water resource system is replenished during the summer season, when two-thirds of the mean rainfall is captured by reservoirs (Government of Mauritius, 2014).

Table 1: Basic Statistics for Mauritius for 2013

Population (millions)	1.217
Urban Population (millions)	0.508
GDP at basic prices (MUR billions / USD billions)	323.2 / 9.1
Per capita GDP at basic prices (MUR / USD) ¹	265,603 / 7,481
Annual real growth rate (%)	3.2
Mean annual rainfall (mm)	2,049
Annual fresh water abstraction (all recorded sectors) (million m ³)	608
Annual fresh water abstraction from surface water (million m ³)	487
Potable water produced (million m ³)	217
(Metered) Potable water consumed (million m ³)	96
Daily per capita domestic water consumption (liters)	165

Notes: ¹ Exchange rate USD 1 = MUR 35.5

Source: Digest of Environment Statistics (2013), Digest of Energy and Water (2013) and National Accounts of Mauritius (2013)

The water distribution systems and facilities have improved significantly over the last 30 years. At present, 99.6 percent of the population are connected to potable water. The present domestic water demand is met from groundwater (55 percent), and surface water (45 percent). However, despite these improvements, the water sector is currently facing serious challenges in mobilizing additional water resources to meet the rising demand from the growth in population and businesses. In addition, the impact of climate change is likely to exacerbate the serious risk of water shortages.

According to a report by the National Economic and Social Council in 2014 (NESC, 2014), some 200 million liters of treated drinking water are lost on a daily basis, mostly through leaky underground pipes. On average, around 35-40 percent is lost in the distribution network and around 10-15 percent is lost to faulty meters or illegal connections; a further 10 percent is explained by unbilled consumption, such as for fire fighting. This loss is equivalent to about four times the annual capacity of the largest reservoir on the island. The waste of such a valuable resource has been going on for decades.

This has serious repercussions for households, many of which have had to install water tanks to ensure a continuous supply of water. The 2000 census for Mauritius recorded that 36.4

percent of households had a water tank or domestic reservoir. This figure rose to 48.1 percent in the 2011 census.⁶

2.4 Water Asset Accounts

There have been a number of initiatives to construct water accounts in Mauritius. In fact, Statistics Mauritius has published a range of information pertaining to water assets and flows in the Digest of Energy and Water Statistics (since 1999) and, more recently, in the Digest of Environmental Statistics. In June 2015, Statistics Mauritius published its first annual water account for Mauritius. The Southern African Development Community, in collaboration with the European Union, compiled a training manual for 'Economic Accounting of Water Use' in Mauritius in 2010 (Arntsen et al., 2010). In addition, the Government of Mauritius and the Indian Ocean Commission (IOC) conducted an experimental ecosystem natural accounting project for Small Island Developing States – as part of the Mauritius Strategy project in the Eastern and Southern Africa and Indian Ocean (ESA-IO) region. This aim of the project was to test the feasibility of ecosystem and natural capital accounting systems using data currently available in Mauritius (Weber, 2014a). With technical assistance from the IOC's ISLANDS project, a case study was developed to present an overview of the first SEEA-Experimental Ecosystem Accounts and Natural Capital Accounts of Mauritius. Natural capital accounts, compiled by Weber (2014a), include land cover accounts, biomass-carbon accounts, water accounts, biodiversity of systems and species accounts, and marine coastal ecosystem accounts. This study builds on previous initiatives to construct water accounts for Mauritius.

2.5 Water Balance

Water data is often recorded on a hydrological year basis, which starts at the onset of the rainy season. In Mauritius, the hydrological year starts in October and ends in September of the following year. The hydrological year has been adjusted to align with calendar year activities – in other words, from January to December. For water accounting, it is assumed that the water stock at the end of the year (pre-accounting year) and the water stock at the beginning of the post-accounting year are equal. However, if the accounts are prepared on a monthly basis, they may show the changes in stock arising from use and replenishment.

The total water from rainfall in Mauritius amounted to 3,821 million m³ in 2013 (Table 2). Table 2 and Figure 2 show the fluctuations in rainfall over the period 2000 to 2013. The lowest amount of precipitation for the period was in 2012. When water flows, part of it flows over the land surface (Proag, 1994). The surface runoff for 2013 is estimated at 2,293 million m³ – 60 percent of the total water from rainfall. Water is partly depleted when it evaporates, transpires or is directed to a sink where it cannot be used again (Chalmers et al., 2012; Karimov et al., 2012). Evaporation is the conversion of liquid precipitation into water vapor, which then returns to the atmosphere (Proag, 1994). Transpiration is the water loss from plants and occurs when the vapor pressure in the air is less than that in the leaves. The

⁶ Households use water tanks and sometimes electrical pumps to cope with service interruptions and insufficient pressure. This may affect the the quality of drinking water at the tap.

combined process is called evapotranspiration and is estimated at 1,146 million m³ (30 percent). The remaining water recharges the groundwater tables.

Table 2: Water Balance, 2009 to 2013 (million m³)

	2008	2009	2010	2011	2012	2013
Rainfall	4,440	4,470	3,368	3,627	3,001	3,821
Surface runoff	2,664	2,682	2,021	2,176	1,801	2,293
Evapotranspiration	1,332	1,341	1,010	1,088	900	1,146
Net recharge to groundwater	444	447	337	363	300	382

Source: Digest of Environment (Statistics Office)

Figure 2 further illustrates the fluctuations in surface runoff, evapotranspiration and net recharge to groundwater over the last 10 years in Mauritius.

Figure 2: Total Rainfall in Mauritius, 2000 - 2013 (million m³)

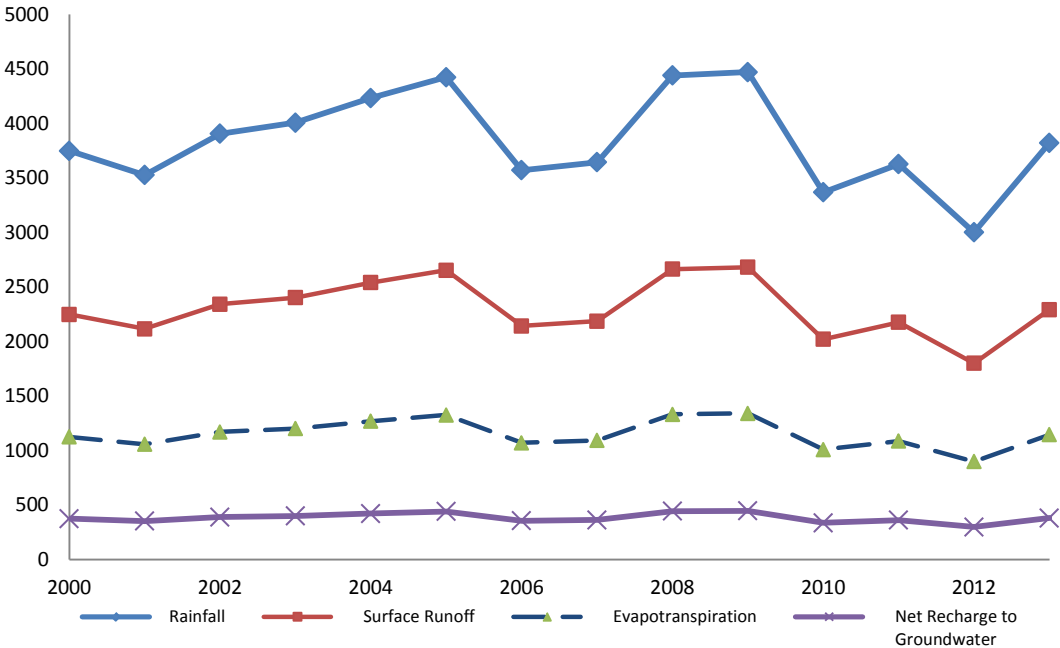

Source: Digest of Environment Statistics (2013)

As Figure 2 shows, there is a close relationship between surface runoff, net recharge to groundwater, and rainfall. Climate change, which may impact on precipitation, is therefore also likely to affect surface runoff and net recharge to groundwater.

Water accounts are constructed for particular spacial domains – in this case the island of Mauritius. Figure 3 provides a map of Mauritius which shows the different amounts (or distribution) of precipitation across the island for 2013.

Figure 3. Distribution of rainfall in Mauritius in 2013

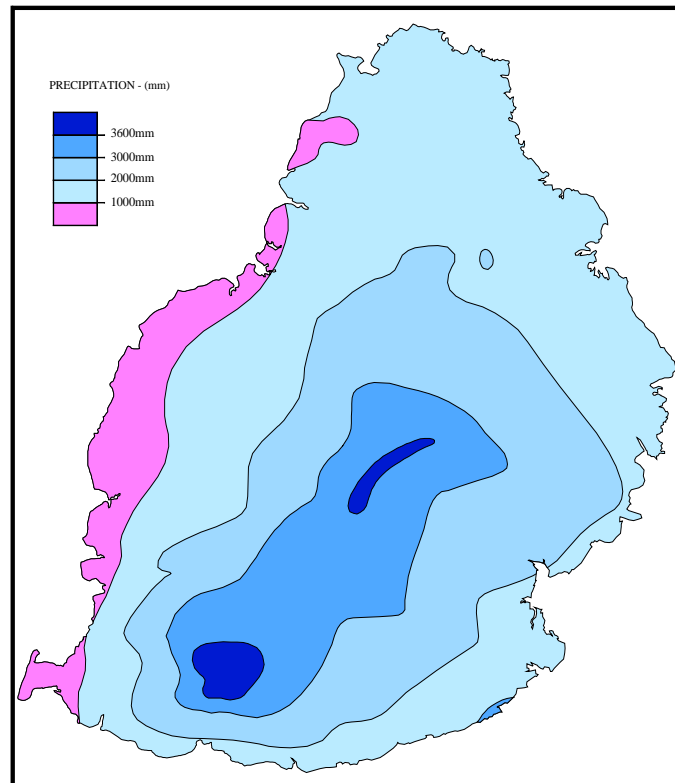

Source: Ministry of Energy and Public Utilities, Hydrology Data Book, 2005

As mentioned earlier in Section 2.3, economic accounting of water is separated into water stock accounts and water flow accounts. Water stock accounts are divided into asset and quality accounts. Asset accounts reflect the amount of total resource and changes in the resource over the accounting period, while the quality accounts record stocks of water in terms of its quality. Water flow accounts record the flow of water from the environment to national economies.

Table 3 shows the water balance in Mauritius for the year 2013. The total amount of rainfall – 3,821 million m³ – is divided into surface runoff, evapotranspiration and net recharge to groundwater. Of the total amount of water from rainfall, 2,675 million m³ (70 percent) is available for exploitation. This is obtained by subtracting the proportion which is attributed to evapotranspiration. The total amount available for exploitation is divided into surface runoff (2,293 million m³) and groundwater (382 million m³). The total water available, also referred to as internal renewable resources, therefore corresponds to the sum of the annual flow of rivers and recharge of groundwater generated from precipitation (UN, 2007) – which in this case amounts to 2,675 million m³.

Table 3: Water Balance in Mauritius, 2013 (million m³)

Water available			Water utilization	
(1)	Rainfall	3,821		
	Surface runoff	2,293		
	Evapotranspiration	1,146		
	Net recharge to groundwater	382		
(2)	Water available for exploitation	2,675		
	Surface runoff	2,293		
	Groundwater	382		
(3)	Water sources for abstraction	608	Water utilization	888
	Surface water	487	in the economy	
	Groundwater	121		
(4)	Water for Hydropower	280		
(5)	Water flowing to sea or to ecological reserve (Flows to sinks)			
	Surface water	1,806		
	Groundwater to sea	427		
	Groundwater addition to closing	106.7		

Source: Author's calculations from Digest of Environment Statistics and Digest of Energy and Water Statistics

From the water available for exploitation, water abstraction is estimated at 608 million m³. The sources are made up of rivers (136 million m³), reservoirs (351 million m³) and groundwater (121 million m³). From an economic perspective, water used for hydropower is also important because it generates wealth; but since the water is returned to the water cycle after utilization and therefore not removed from the total water available for exploitation, it is not counted as an abstraction. The difference between water available for exploitation and water abstraction shows the total amount which flows either to the sea or to ecological reserves. This is referred to as 'flow to sink' in the SEEA-Water terminology (UN, 2012). During the year, a certain amount of water consumption from surface water will also flow to groundwater. This is accounted for in the flow account. Thus, surface water and groundwater are the two sources for replenishing the stock of water in the economy.

2.7 Total Water Abstraction: Sources and Users

Water is abstracted for use from two sources: surface water runoff and groundwater. In 2013, 608 million m³ of water was abstracted (Table 4), of which 487 million m³ came from surface water runoff and 121 million m³ from groundwater.

Table 4: Sources of Total Water Abstraction, 2008-2013 (million m³)

Sources	2008	2009	2010	2011	2012	2013
Surface water	546	511	513	449	460	487
Groundwater	143	121	124	122	122	121
Total	689	632	637	571	582	608

Source: Digest of Environment Statistics

Figure 4 shows water abstraction for the years 2000 to 2012. A comparison of Figure 2 and Figure 4 reveals that the amount of rainfall has a significant influence on water abstraction.

Figure 4: Water Abstraction in Mauritius, 2000 to 2012 (million m³)

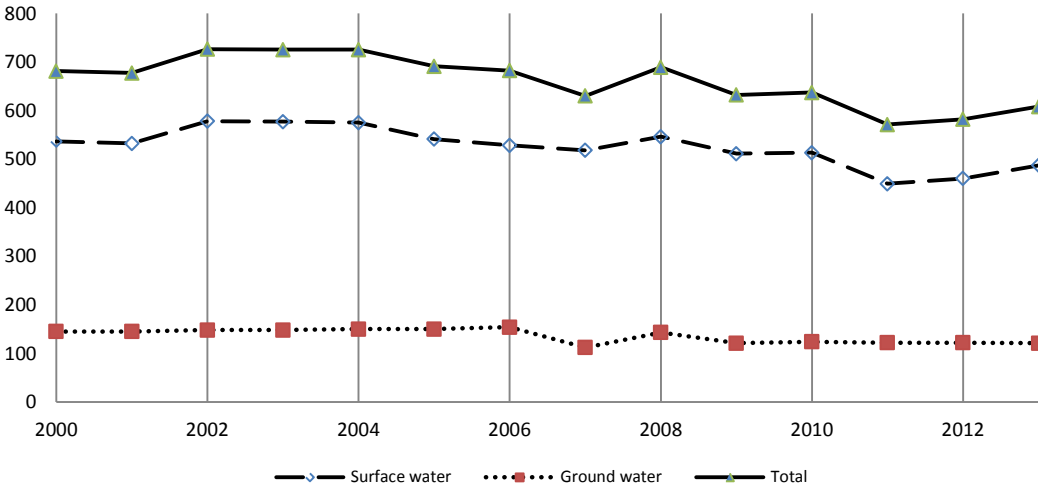

Source: Digest of Environment (Statistic Office)

Table 5 shows the water abstraction account for 2013 with further details on users. The left-hand column shows the total amount used to generate economic activities, which amounts to 888 million m³. The right-hand column, shows the uses of water and the sources for each. Of the 888 million m³, 487 million m³ came from surface water and was used by the water supply industry, the manufacturing industry and agriculture. 280 million m³ was used for hydropower, implying a total surface water abstraction of 767 million m³. The remainder is made up of groundwater, with figures showing the amount used by the water supply industry, the manufacturing industry and agriculture. Table 5, excluding the hydropower component, is similar in structure to a GPWA Statement of Water Assets and Water Liabilities; the right-hand column shows the water assets while the left-hand column depicts the water liabilities.

Table 5: Water Abstraction Account, 2013

Water sources for abstraction		Utilization	
Total water abstraction	888	Total water utilization	888
Surface water	487	Surface water	487
Rivers	136	Water supply industry	112
Reservoirs	351	Manufacturing	7
		Agriculture, forestry and fishing	368
Surface water to Hydro	280	Hydropower	280
Groundwater	121	Ground water	121
		Water supply industry	108
		Manufacturing	6
		Agriculture, forestry and fishing	7

Source: Author's own calculations from Digest of Environment Statistics and Digest on Energy and Water Statistics

2.8 Water Abstracted by the Water Supply Industry

The water supply industry supplies the economic and household sectors in Mauritius. Water abstraction for these sectors is the main focus for investment strategies and pricing policies. Following abstraction, the water is treated before it is distributed. Water withdrawal by the water supply industry in Mauritius stood at 220 million m³ for the year 2013. As expected, this amount is dependent on the storage system. There are 11 storage systems – reservoirs, dams and lakes – which store water to be distributed to the population. Table 6 shows the capacity of these reservoirs.

Table 6: Storage Capacity of Reservoirs in Mauritius

Reservoir	Capacity (million m ³)	District	Purpose
Mare aux Vacoas	25.89	Plain Wilhems	Domestic
Mare Longue	6.28	Plain Wilhems	Hydropower and irrigation
La Ferme	11.52	Black River	Irrigation
Piton du Milieu	2.99	Moka	Domestic
La Nicoliere	5.26	Pamplemousses	Domestic, irrigation and industrial
Tamarind Falls	2.3	Black River	Hydropower and irrigation
Eau Bleue	4.1	Grand Port	Hydropower
Diamamouve	4.3	Grand Port	Hydo-power
Dagotiere	0.6	Moka	Hydo-power
Valetta	2	Moka	Hydo-power
Midlands Dam	25.5	Moka	Domestic, irrigation and industrial
Total Storage Capacity 90.74			

Source: Digest of Energy and Water (2013)

The distribution network in Mauritius works on a regional basis, with each of the reservoirs (above) supplying particular networks or regions. There are six regions as shown in Table 7.

Table 7: Water Sources by Regions

Regions	Sources	Water for distribution (million m ³)
Mare Aux Vacoas (Upper)	Surface	43.2
	Borehole	6.6
	Total	49.8
Mare Aux Vacoas (Lower)	Surface	0.0
	Borehole	30.0
	Total	30.0
Port –Louis	Surface	20.5
	Borehole	13.2
	Total	33.7
District water supply - North	Surface	26.3
	Borehole	21.3
	Total	47.6
District water supply - South	Surface	9.7
	Borehole	16.7
	Total	26.4
District water supply - East	Surface	9.4
	Borehole	19.7
	Total	29.1
Whole Island	Surface	109.1
	Borehole	107.5
	Total	216.6

Source: Digest of Energy and Water Statistics (2013)

The water resource system in Mauritius is highly influenced by seasonal variations in rainfall. As mentioned earlier, the average annual precipitation over the island is 2,000 mm but the rate of replenishment of the water resource systems differs across the year. Table 8 shows the months when water levels are at their highest and lowest.

Table 8: Minimum and Maximum Water Levels in Mauritius

Reservoir	Capacity (million m ³)	Minimum – as a % of capacity (month(s))	Maximum - as a % of capacity (month(s))
Mare aux Vacoas	25.89	52 (January)	100 (April)
Midlands Dam	25.5	37 (January)	100 (March and April)
La Ferme	11.52	21 (January and November)	100 (March and April)
Mare Longue	6.28	36 (January)	100 (April)
La Nicoliere	5.26	39 (October and November)	100 (February to May)
Piton du Milieu	2.99	27 (January)	100 (February to April)

Source: Digest of Energy and Water (2013)

Table 9: Water Abstraction by Water Supply Industry, 2003-2013 (million m³)

Sources	2003	2004	2005	2006	2007	2008	2009	2010	2011	2012	2013
Surface water	110	110	99	100	102	107	112	110	94	97	112
Groundwater	114	114	115	116	99	107	111	113	111	109	108
Total	224	224	214	216	201	214	223	223	205	206	220

Source: Digest of Environmental Statistics

Table 9 shows the amounts of water abstraction by the water supply industry over a ten year period, from 2003 to 2013. A comparison with Table 2, reveals that only 8 percent of water available is abstracted by the water supply industry annually. This indicates that Mauritius is a water rich country.

Table 10 shows the uses of water from the water supply industry. This information corresponds to the allocation of accounts according to the GPWA. As can be clearly observed from the table, the distribution loss amounts to 110 million m³.

Table 10: Water Account for the Water Supply Industry, 2013 (million m³)

Water use by sectors	million m ³
Domestic	73.36
Government	3.80
Acquired / concessionary prizes	0.01
Commercial	6.98
Hotels, guest houses	6.05
Industrial	3.78
Shipping	0.00
Vegetable and livestock producers	1.3
Sub-total	95.86
Total non-treated water (agriculture/industrial)	15.4 2
Total water requirements from water industry	111
Distribution loss ⁷	110
Water abstracted by Water Supply Industry	220

Source: Digest of Energy and Water Statistics (2013)

2.9 Physical Flow Account of Water: Supply and Use Table

Tables 11 and 12 show the supply and use tables for Mauritius in 2013. The work follows a draft report and capacity building which was prepared by Statistics Mauritius with the support of the UN Statistics Division (UNSD).⁸ The Physical Water Supply and Use Table (PSUT) is based on the concepts outlined in Section 2.4 and contains relevant data on water flows. The water supply table focuses primarily on the flow of water from the environment to the economy, to households and the return flows back to the environment; while the use table focuses mainly on the flow of water within the economy and household sector, and the return flows back to the environment. Tables 13 and 14 present a simplified version of the full PSUT. The household sector is treated separately from the economic sectors given that water is used as an intermediate product in the productive sectors while it is consumed as a final product in the household sector.

Flows of water in the economy are distinguished between household⁹ and economic sectors. These sectors *use* water and at the same they *supply* water. We divide the economy into seven sectors – namely, agriculture and livestock, manufacturing services, hydroelectricity, cooling of thermoelectricity, water utilities, sewage¹⁰ and household. The environment is

⁷ The term distribution loss follows the definition of the terminology for water accounts given earlier. It does not necessarily mean that this amount of water is lost through leaky pipelines. It might also pertain to commercial losses, i.e., faulty meters and illegal connections. Therefore, the meaning of the term ‘distribution loss’ as used here is closer to the term Non-Revenue Water.

⁸ Our thanks go to Ricardo Martinez-Lagunes, Inter-Regional Advisor on SEEA at the UNSD, for having made crucial data available to us.

⁹ The word ‘residential’, ‘household’ and ‘domestic’ are used interchangeably in this research report.

¹⁰ The sewage sector refers to man-made facilities to collect used water.

considered as an additional sector as it both supplies and uses water. Surface water (through the environment) forms the bulk of the water supply to the economy and to households, estimated at 767 million m³ in 2013. The second environmental component, groundwater, supplies 212 million m³ (see Table 11).

Table 11: Supply Table for Water, 2013

SUPPLY	Agriculture and livestock	Manufacture and services	Hydroelectricity	Cooling (thermoelectricity)	Water utilities (drinking water)	Sewerage (sewage collection and treatment)	Households	Environment to economy	TOTAL
Surface water								767	767
Groundwater								121	121
Total supply								888	888
Water supply industry: treated water					96				96
Water supply industry: non-treated water					15.4				15.4
Water supply industry: loss through distribution					108.6				108.6
Sewage to sewers		7					34		41
Sewage to environment							28		28
Treated wastewater		21				41			62
Water returns to the environment	114		280						394
Evaporation, transpiration, incorporation in products	262	6	0	0	0	0	11.3		281
TOTAL	376	34	280	0	220	41	73	888	1025

Source: Author's own calculations

A total of 888 million m³ of water is available for abstraction and hydropower (Table 5). Of this, water utilities treat 220 million m³ of water, defined as 'potable' water. However, only 96 million m³ of water is consumed by households. The rest is a loss to the economy – reflected in water flow accounts as *losses of water* – which amounts to 124.1 million m³. 'Losses of water' are divided into the losses from the water supply industry of non-treated

water – which is distributed to the agriculture/manufacturing sectors – and from ‘distribution loss’ attributed to ‘Non-Revenue Water’.

From the total of 767 million m³ of surface water supplied by the environment to the economy, the agriculture and livestock sector consumed 368 million m³. This sector also consumed 7 million m³ and 1.3 million m³ from groundwater and drinking water, respectively. This equates to a total of 376 million m³. In the supply table (Table 12), this water will have to flow to one or more sectors. While a significant proportion evaporates, the rest is counted as a supply to an entity called *water returns*. Assuming a proportion for evaporation, transpiration and incorporation in products, a total of 114 million m³ returns to the environment. This is assumed to be ‘used’ by the environment in the use table. Water for hydropower has a specific characteristic since it goes back to the environment after being used. 280 million m³ is used for hydropower, which then flows back to the environment – *water returns*. The total water returns to the environment, therefore, amount to 395 million m³. The manufacturing sector uses 34 million m³ of water from surface water, groundwater and drinking water. This amount of water flows back to *sewage to sewers* and *treated wastewater*. The household sector uses 73.4 million m³ of water. This amount comes from the *drinking water* but then returns the water back to *sewage to sewers* and *sewage to environment*.

Water is abstracted from surface water (reservoirs and rivers) and groundwater. The agricultural sector was the main user of water (376.3 million m³), followed by the water supply industry. In Mauritius, the water supply industry is composed of one central, public agency, the Central Water Authority (CWA). Water abstracted by the CWA is mainly used for drinking water purposes and accounted for 73.4 million m³ in 2013. Water was also received by the sewerage sector and amounted to 41 million m³.

Return flows refer to water returned to the environment after use in agriculture (irrigation), waste water or through distribution losses such as leaking pipelines. The return was estimated at 395 million m³. The distribution loss amounted to 110 million m³ but is recorded as 124 million m³ to take into account the non-treated water (15.4 million m³). The distribution loss is equivalent to 50 percent of the total supplied by the CWA (220 million m³). This figure is seriously high and poses questions about the management of the water sector in Mauritius. However, this figure must be treated with caution since it does not mean that 50 percent of the total water supplied is lost through leaky pipelines. As previously mentioned, the category *distribution loss* also includes other forms of water losses, such as commercial losses – closely related to what is typically referred to as Non-Revenue Water. The use table also shows that 41 million m³ of sewage flowed to sewers and 28 million m³ flowed to the environment. In addition, 62 million m³ of wastewater was treated prior to discharge or reuse.

Table 12: Use Table for Water, 2013

USE (million m ³)	Agriculture and livestock	Manufacturing and services	Hydroelectricity	Cooling (thermoelectricity)	Water utilities (drinking water)	Sewerage (sewage collection and treatment)	Households	Economy to environment	TOTAL
Surface water	368	7	280	0	112				767
Groundwater	7	6	0	0	108				121
Total abstraction	375	13	280		220				888
Water supply industry: treated water	1.3	21					73.4		95
Water supply industry: non-treated water									15.4
Water supply industry to the environment, including distribution loss								108.6	108.6
Sewage to sewers						41		0	41
Sewage to environment								28	28
Treated wastewater								62	62
Water returns to the environment								395	395
Evaporation, transpiration, incorporation in products								280	280
TOTAL	376	34	280	0	220	41	73.4	888	1025

Source: Author's own calculations

The supply table shows that returns mainly comprised of sewage and water losses. Households discharged 34 million m³ to sewers and an estimated 28 million m³ went directly to the environment. The total amount of treated wastewater returns (62 million m³) were from industries (21 million m³) and households (41 million m³). Water returns (395 million m³) included 280 million m³ from non-consumptive use for hydropower and 114 million m³ from agriculture. Agriculture accounted for most of the consumptive use – 262 million m³ out of the total of 281 million m³.

It is important to add a caveat at this point. Some of the water flows, particularly the returns, losses and consumptions were estimated as differences between other flows and the total. For instance, the amount of water consumed in households was estimated by subtracting the total wastewater discharged (sewage) from the water use (total received); thus, balancing the supply and use columns, and row totals.

2.10 Water Abstraction at Regional and Seasonal Levels

Tables 11 and 12 provide an annual use and supply table for water. Given that around 3,821 million m³ of water was obtained through precipitation, 220 million m³ of water was abstracted by the water supply industry, and 110 million m³ of water was consumed, it appears that there is no visible water scarcity in Mauritius. Table 13 adjusts the amount of water abstracted and water used by accounting for the 50 percent distribution loss (i.e., Non-Revenue Water). On average, water consumption stands roughly at 9.3 million m³ per month (dividing the annual consumption by 12). This figure can then be compared with water production on a monthly basis. Taking into account the loss of water – which stood at 50 percent – the water available for consumption from the water utility service is estimated at an average of nine million m³ per month. Compared with the monthly consumption of water – 9.3 million m³ – there is a gap of 0.3 million m³ a month. As shown in Table 13, during the months of September, October, November, and February water production is relatively low due to the limited seasonal rainfall. These are periods of water scarcity. Households in certain regions of Mauritius do not have 24 hour access to water and often experience severe cuts in supply.

Table 13: Estimates of Water Requirements and Water Production on a Monthly Basis

Month	Monthly water production million m ³	Monthly water available for consumption million m ³	Monthly water requirements - million m ³
Jan	18.0	9.0	9.3
Feb	16.6	8.3	9.3
Mar	19.7	9.9	9.3
Apr	18.9	9.5	9.3
May	19.5	9.8	9.3
Jun	18.0	9.0	9.3
Jul	18.5	9.3	9.3
Aug	18.2	9.1	9.3
Sep	17.2	8.6	9.3
Oct	17.2	8.6	9.3
Nov	16.9	8.5	9.3
Dec	17.9	9.0	9.3

Source: Statistics Mauritius and author’s own estimates

Figures 5,6 and 7 illustrate water shortages in three regions of Mauritius: the North, South and Central regions. These figures show that while the level of water from the water supply industry is much higher than the level of potable water consumption, accounting for

distribution losses (i.e., Non-Revenue Water) of around 50 percent makes a significant difference. In fact, with the level of distribution losses, the current level of available water is nearly equivalent to water demand. During the months of December to January, a significant drop in water abstraction is observed, implying an associated fall in consumption.

Figure 5: Production of Potable Water Versus Water Demand, Northern Region

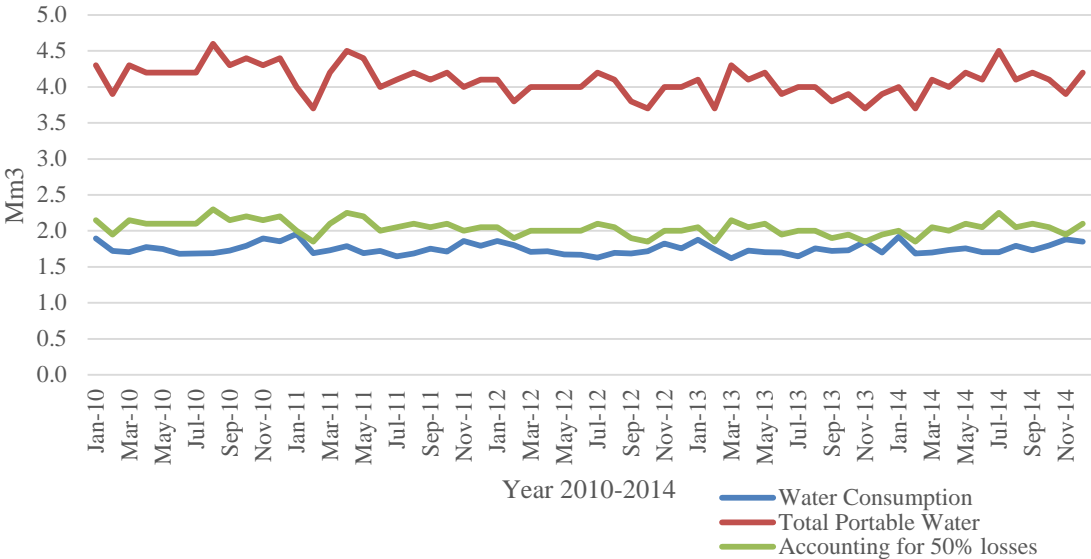

Source: Information from Central Water Authority and author’s own estimates

Figure 6: Production of Potable Water Versus Water Demand, Southern Region

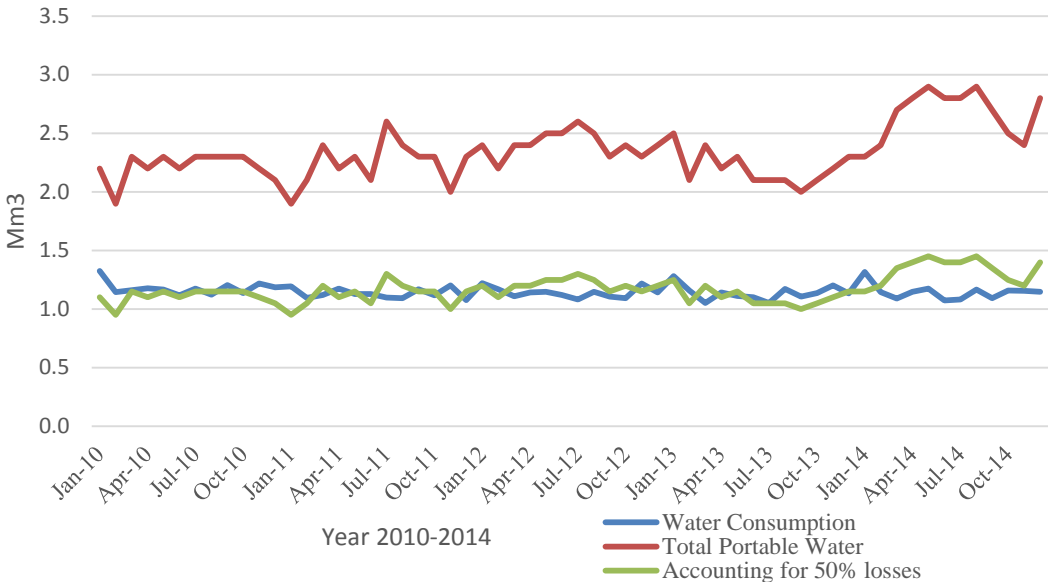

Source: Information from Central Water Authority and author’s own estimates

Figure 7: Production of Potable Water Versus Water Demand, Central Region

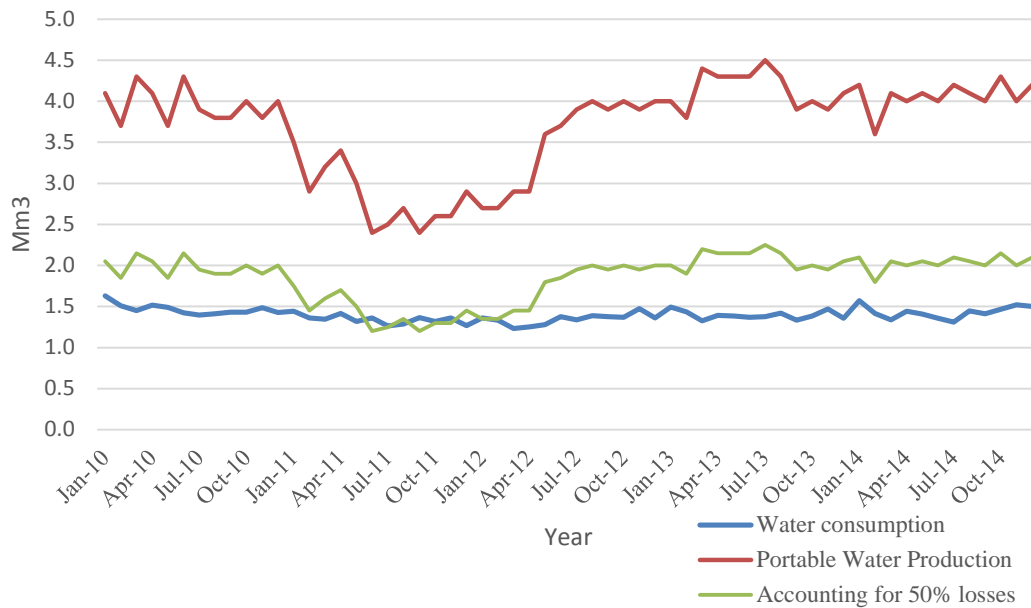

Source: Information from Central Water Authority and author’s own estimates

Shortages of water are witnessed mainly for the north and the south as shown in figures 5 and 6. The water situation is particularly acute for the southern region of the island, where water consumption in some months is greater than water production – implying water has to be transferred from other reservoirs to satisfy the demand in this region.

2.11 Seasonal Water Accounts

Tables 14 to 18 show the water accounts for the summer and winter seasons. Around 77.5 percent of rainfall is observed in the months from November to April; and the remainder in winter, from May to October. Table 14 shows the uneven distribution of rainfall between the seasons in 2013: 2,072 million m³ of water was available for exploitation in summer and 862 million m³ in winter. 455.2 million m³ and 152 million m³ of was abstracted, respectively, in these two periods.

Table 14: Seasonal Water Balance, 2013 (million m³)

	Summer	Winter
Rainfall	2,960	862
Surface runoff (million m ³)	1,776	517
Evapotranspiration (million m ³)	888	258
Net recharge to groundwater	296	96
Water available for exploitation	2,072	613
Surface runoff	1,776	517
Groundwater	296	96
Water resources abstracted	455.4	152.7
Surface water	393.6	93.5
Ground water	61.8	59.2

Source: author’s own calculation

Table 15 shows the total water abstraction on a seasonal basis for 2013. Surface water available for abstraction varies significantly: 393.6 million m³ in summer and 93.5 million m³ in winter. The agricultural and forestry sub-sector is most vulnerable in the winter season when precipitation levels are at their lowest.

Table 15: Total Water Abstraction on Seasonal Basis, 2013 (million m³)

Water sources for abstraction	Water utilization	Summer	Winter
Surface water		393.6	93.5
	Water supply industry (CWA)	57.1	55
	Manufacturing	4	3
	Agriculture, forestry and fishing	332.5	35.5
Surface water to hydro		219.0	61.0
Groundwater		61.8	59.2
	Water supply industry (CWA)	54.4	53.6
	Manufacturing	3.4	2.6
	Agriculture, forestry and fishing	4	3
Total		601	287

Table 16 shows water abstraction by the water supply industry. The demand for the different sectors is more or less constant, implying that the uneven distribution of rainfall must be stored to allow a consistent distribution during the year.

Table 16: Water Abstraction by Water Supply Industry on a Seasonal Basis, 2013 (million m³)

Water users	Million m ³	
	Summer	Winter
Domestic consumers	37.3	36.1
Business consumers	3.5	3.4
PSA consumers	1.9	1.9
Industrial	1.9	1.9
Agricultural	1	0.3
Commercial consumers	3.0	3.0
Concession price	0.0	0.0
Religious and charitable	0.3	0.3
Sub-total	48.6	47.3
Total non-treated water (agriculture/Industrial)	7.8	7.6
Total water requirements from water industry	56.4	54.9
Distribution loss ¹	53.9	54.1
Water abstracted	110.3	109.0

Note: ¹ Distribution loss refers to the category used by the SEEA and is in fact closer to Non-Revenue Water, as previously discussed

Source: author's own calculation

Tables 17 and 18 provide the supply and use tables for the summer and winter seasons, respectively. Demand for water is fairly stable over the year but water availability is dependent on the hydrological cycle. Very low amounts of precipitation in winter lead to a lower water supply during this period, which, in turn, results in large disparities between supply and use. The storage and distribution systems have to cope with these disparities and cater for the need to continuously provide sufficient water to the population.

Table 17: Supply and Use Table for Summer Season, 2013

SUPPLY	Agriculture and livestock	Manufacturing and services	Hydroelectricity	Cooling (thermoelectricity)	Water utilites (drinking water)	Sewerage (sewage collection and treatment)	Households	Environment to economy	TOTAL
Surface water								420.3	420.3
Groundwater								68.4	68.4
Water supply industry: treated water					49.06				49.06
Losses of water					62.4				62.44
Sewage to sewers		3.7					17.2		20.8
Sewage to environment							14.2		14.2
Treated wastewater		11.4				22.6			34.0
Water returns	101.3		219.0						320.2
Evaporation, transpiration, incorporation in products	236.3	3.3	0	0	0	0	6.0		245.5
TOTAL	337.5	18.5	219.0	0	111.5	22.55	37.3	488.7	1,235.0
USE (million m ³)	Agriculture and livestock	Manufacturing and services	Hydroelectricity	Cooling (thermoelectricity)	Water utilites (drinking water)	Sewerage (sewage collection and treatment)	Households	Economy to environment	TOTAL
Surface water	332.5	4.0	219.0	0.0	57.1				612.5
Groundwater	4.0	3.4	0.0	0.0	54.4				61.8

Water supply industry: treated water	1.0	11.0					37.3		49.3
Losses of water								68.3	68.3
Sewage to sewers						22.6		0.0	22.6
Sewage to environment								15.4	15.4
Treated wastewater								34.1	34.1
Water returns								217.3	217.3
Evaporation, transpiration, incorporation in products								153.7	153.7
TOTAL	337.5	18.5	219.0	0.0	111.5	22.6	37.3	488.7	1,235.0

Table 18: Supply and Use Table for Winter Season, 2013

SUPPLY	Agriculture and livestock	Manufacturing and services	Hydroelectricity	Cooling (thermoelectricity)	Water utility (drinking water)	Sewerage (sewage collection and treatment)	Households	Environment to economy	TOTAL
Surface water								343.9	343.9
Groundwater								56.0	56.0
Water supply industry: treated water					47.8				47.8
Losses of water					60.8				60.8
Sewage to sewers		3.1					16.6		19.7
Sewage to environment							13.7		13.7
Treated wastewater		9.6				18.45			28.1
Water returns	11.64		61.02						72.7
Evaporation, transpiration, incorporation in products	27.16	2.8	0	0	0	0	5.8		35.7
TOTAL	38.8	15.5	61.02	0	108.6	18.45	36.1	399.9	678.3

USE (million m ³)	Agriculture and livestock	Manufacture and services	Hydroelectricity	Cooling (thermoelectricity)	Water utility (drinking water)	Sewerage (sewage collection and treatment)	Households	Economy to environment	TOTAL
Surface water	35.5	3.0	61.0	0	55				154.6
Groundwater	3	2.6	0	0	53.6				59.2
Water supply industry: treated water	0.3	9.9					36.1		46.3
Losses of water								55.8	55.8
Sewage to sewers						18.45		0.0	18.5
Sewage to environment								12.6	12.6
Treated wastewater								27.9	27.9
Water returns								177.8	177.8
Evaporation, transpiration, incorporation in products								125.8	125.8
TOTAL	38.8	15.5	61.0	0	108.6	18.5	36.1	399.9	678.3

References

Biltonen, E. and Dalton, J. A. (2003). A Water-Poverty Accounting Framework: Analyzing the Water-Poverty Link. Vol. 28, No.4, pp.467-477.

Burrell M., Moss P., Petrovic J., Ali A. (2012). General Purpose Water Accounting Report 2011-2012 - Gwydir catchment, NSW Department of Primary Industries, Sydney.

Chalmers, K., Godfrey, J. and Potter, B. (2012). Discipline-Informed Approaches to water Accounting. *Australian Accounting Review*, Vol, 22. No.62, pp.275-285.

Food and Agriculture Organization (2012). United Nations Food and Agriculture Organization. Aquastat Database, www.fao.org/nr/water/aquastat/main/index.stm (30.09.2014).

Government of Mauritius (2014). National Water Policy. Ministry of Energy and Public Utilities. Government of Mauritius.

International Environment Agency (2012). Water for Energy: Is Energy Becoming a Thirstier Resource? Excerpt from the World Energy Outlook 2012, p. 3. Paris: International Energy Agency IEA online.

Isnard, L. And Barraqué, B. (2010). *Bibliographie commentée*. Deliverable 1 of the research project Eau&3E – La durabilité des services d'eau dans les grandes villes. Project funded by the French Research Agency (*Agence Nationale de la Recherche*).

Karimi, P., Molden, D., Bastiaanssen, W and Xueliang, C. (2012). Water accounting to assess to use and productivity of water: evolution of a concept and new frontiers. In 'Water Accounting International Approaches to Policy and Decision-Making. Edited by Godfrey, J. M. and Chalmers, K. Edward Elgar Publishing Limited, The Lypiatts 15 Lansdown Road, Cheltenham, Glos GL50 2JA. UK. ISBN 978 1 84980749 4

Karimov, A., Molden, D., Khamzina, T., Platonov, A., Ivanov, Y. (2012). A water accounting procedure to determine the water savings potential in Fergana Valley. *Agriculture Water Management*, vol.108, pp.61-72.

Lange, G. M. (2007). Editorial: Environmental accounting: introducing the SEEA-2003. *Ecological Economics*, vol.61, pp.589-591.

Lange, G. M. An Approach to Sustainable Water Management Using Natural Resource Accounts: the Use of Water, the Economic Value of Water, and Implications for Policy. Research Discussion Paper, vol.18, Directorate of Environmental Affairs Ministry of Environment and Tourism Private Bag 13306 Windhoek, Namibia.

Lange, G. M. and Hassan, R. (2006). Introduction to water issues and water accounting in Southern Africa. *The Economics of Water Management in Southern Africa – An Environmental Accounting Approach*.

Lange, G-M., Mungatana, E., and Hassan, R. (2007). Water Accounting for the Orange River

- Basin: an economic perspective on managing a transboundary resource. *Ecological Economics*, vol.61, pp. 660-670.
- Meinzen, R. and Ringler, C. (2006). Water Reallocation: Challenges, Threats and Solutions for the Poor. Human Development Report Occasional Paper, vol.41.
- Molden, D. (1997). Accounting for water use and productivity. SWIM Paper 1. Colombo, SriLanka: International Irrigation Management Institute
- Molden, D. and Sakthivadivel, R. (1999). Water Accounting to Assess Use and Productivity of Water. *Water Resources Development*, vol.15, Nos. 1/2, pp.55-71.
- Moran, D and Dunn, S. (2008). The economic value of water use: Implications for Implementing the Water Framework Directive in Scotland. *Journal of Environmental Management*, Vol. 87, pp.484-496.
- National Economic and Social Council. (2014). Management of Water Resources. NESC Report No. 28.
- Repetto, R., Magrath, W., Wells, M., Beer, C., Rossini, F. (1989). Wasting Assets: Natural Resources in the National Accounts. World Resources Institute, Washington.
- United Nations. (2012). SEEA-Water System of Environmental-Economic Accounting for Water. ST/ESA/STAT/SER.F/100 United Nations publication.
- Vardon, M., Lenzen, M., Peavor, S., and Creaser, M. (2007). Water accounting in Australia. *Ecological Economics*, vol.61, pp.650-659.
- Weber J L (2014a) Experimental Ecosystems Natural Capital Accounts Mauritius Case Study, Methodology and preliminary results 2000–2010, Indian Ocean Commission, June 2014.[http:// commissionoceanindien.org/fileadmin/resources/Islands/ENCA_Mauritius.pdf](http://commissionoceanindien.org/fileadmin/resources/Islands/ENCA_Mauritius.pdf) (accessed 10 September).
- Weber J L (2014b) *Ecosystem Natural Capital Accounts: A Quick Start Package*. Montreal, Technical Series No. 77, Secretariat of the Convention on Biological Diversity, 248 pages
- WWAP (United Nations World Water Assessment Programme). (2015). The United Nations World Water Development Report 2015: Water for a Sustainable World. Paris, UNESCO
- Zhu, Z., Giordano, M., Cai, X., and Molden, D. (2004). The Yellow River Basin: Water Accounting, Water Accounts, and Current Issues. *Water International*, Vol.29, No. 1, pp. 2-10.

Chapter 3: Trends in Water Use, Economic Value of Water, and a Scenario-based Analysis of Water Demand and Supply for 2030

Riad Sultan

Introduction

Chapter 3 has two main objectives: (i) to provide a detailed analysis of the demand for water in Mauritius and (ii) to forecast water demand for the residential and non-residential sectors for the period 2016-2030. To meet the first objective, it estimates the price and income elasticity of water in the residential sector and non-residential sector using an autoregressive distribution lag model (ARDL). The demand for water in productive sectors is also analyzed in terms of the output elasticity and marginal productivity, using a trans-log production function. The chapter then goes on to estimate the economic value of water and contributes to a partial monetary account of water following the work of Wang and Lall (2002), Hassan and Farolfi (2005), Lange and Hassan (2006), Lange et al. (2007) and Ku and Yoo (2012).

The forecasts of water demand for the period 2016 to 2030 take into account the rise in population, economic activities and the impact of climate change on precipitation. Residential and non-residential water consumption is analyzed separately by using an ARDL. Three demand-side scenarios are constructed – low, moderate and high – corresponding to an economic growth of 2 percent, 5.5 percent and 7 percent, up to 2030. On the supply side, an adjustment is made to consider the effects of climate change in Mauritius using the projections made by McSweeney et al. (2010), under the three emission scenarios, A1B, A2 and B2 (IPCC, 2000). Combining the use and availability of water, the study provides estimates of water shortages by 2030.

The chapter is organized as follows: Section 3.1 is devoted to a brief review of the literature on water as an economic good. This is followed in Section 3.2 by a description of water utilization in Mauritius. Section 3.3 provides an estimate of price and income elasticity of water in the residential sector. This section includes the relevant literature, the conceptual framework and the econometric method, data and results. It calculates price and income elasticity by estimating a demand function for residential water. Section 3.4 models the demand for water using the marginal productivity approach and calculates the output elasticity, the marginal productivity of water and the price elasticity in the manufacturing sectors using a trans-log production function. Section 3.5 forecasts the demand for water in both the residential and non-residential sectors under three economic growth scenarios for the period 2015 to 2030 and estimates shortages for the year 2030 using different climate change storylines. The last section, Section 3.6, provides a brief analysis of the behavior of households facing water shortages using the responses to the household survey conducted as part of this study.

3.1 Water as an Economic Good

The fourth Dublin principle¹¹ states that water has an economic value and should be recognized as an economic good, and that any considerations of water use should address affordability and equity criteria (ICWE, 1992). Water generates utility for humans directly when it is consumed or used, and indirectly through the production of other activities (Savenije, 2002). Water is scarce and entails competing uses. Its use in a specific way involves opportunity costs. These correspond to the value of the best alternative forgone – in other words, the alternative which had to be given up in order to use the water in the way chosen. Once water has been defined as an economic good, the concept of opportunity costs allows us to calculate the utility derived from its use and to estimate the benefits. Water has an economic value because of its particular specificities. According to Savenije (2002), water is essential, scarce, fugitive (if it is not captured, it is gone), bulky, non-substitutable, and is not freely tradable.

Water has other specific characteristics: water can be captured but it is bound by its location or origin and natural conveyance system; there are high production costs involved when re-allocated to the storage system; and the market for water is heterogeneous – while some groups of people are willing to pay (high prices), others are not (for example, farmers).

The economic value of water is an important element in its management. According to Rogers et al. (2002), the value of water relates to the benefits to users, the benefits from returned flows, the indirect benefits and its intrinsic value. An estimation of the value of water can be used to price it efficiently (one of the many objectives of water management).

The concept of 'total economic value', which refers to the benefits people derive from an environmental or natural resource, can be used to measure the value of water. Two main categories are identified:

1. Use values. These are further differentiated into
 - (i) Direct use values. These arise from direct interaction with water resources. They may be consumptive such as water for irrigation or non-consumptive such as recreational swimming.
 - (ii) Indirect use values are associated with services provided by water resources.
2. Non-use values are derived from maintaining the resource arising out of ethical concerns or altruistic preferences. Non-use values can exist in three different types:
 - (i) Existence values. These corresponds to the satisfaction which is derived by the mere fact that the water resource continues to exist, regardless of whether or not it is being used.

¹¹ The Dublin Statement on Water and Sustainable Development, also known as the Dublin principles, sets out recommendations to reduce water scarcity.

- (ii) The bequest value. This pertains to the utility which is derived by future generations and relates to the idea of ensuring intergenerational equity.
- (ii) The philanthropic value. This is the satisfaction gained from guaranteeing that resources are available to the current generation (Turner et al. 2004).

From the above theoretical underpinning, a number of market and non-market valuation approaches have been developed.

In England and Wales, the value of water use has been assessed by comparing the contribution of different sectors to the economy (Moran and Dann, 2008). In contrast, the economic valuation for Scotland adopts a variety of approaches, where the choice is dictated by the availability of data on revealed values through the market for water services.

This section uses the use and supply tables constructed in the previous chapter to estimate the economic value of water. In fact, the value of water can be extracted from its use in different sectors of the economy. For example, users in the residential sector derive a benefit and the economic welfare of such consumption can be estimated. The value of water used as an intermediate input in economic activities can also be extracted using a productivity approach. The following section is restricted to the water supplied by the Central Water Authority (CWA). However, a more comprehensive estimation of the value of water includes groundwater used directly by the agricultural and industrial sectors, as well as the non-use value associated with water flowing to sinks.

To conceptualize the economic value of water, it is important to differentiate between final water consumption in the residential sector and water used in the production sectors. For this reason, the following section treats each of the two sectors separately.

3.2 Water Utilization in Mauritius

Water consumption in Mauritius for 2013 is shown in Table 19. The highest proportion of potable water went to the domestic sector, which has more than 317,000 subscribers. The domestic sector consumed a total of 73.4 million m³. The manufacturing, business and commercial sectors also consumed potable water, as shown below. However, the agricultural and manufacturing sectors also used non-treated water supplied by the CWA. The non-treated water is distributed to users through a separate water pipe system.

Table 19 also shows the average price per cubic meter: the average price for potable water was MUR 13.44 (USD 0.38) per cubic meter and MUR 3.91 (USD 0.11) for non-treated water. An important question is whether this constitutes a 'fair price'. Evidently, this cannot be answered without a proper analysis of the cost structure, the ability of households to pay and the economic contribution of water.

Table 19: Water Consumption in Mauritius, 2013

Water consumption	Subscribers		Volume sold		Amount collectible		Average consumption (m ³)	Average price per m ³
	No.	%	million m ³	%	MUR (USD) millions	%		
Households	317,786	92.9	73.4	65.9	696.3 (19.61)	51.6	231	9.49
Public sector agencies	2,511	0.7	3.8	3.4	91.1 (2.57)	6.8	1,512	24.00
Acquired / concessionary prices	38	0.0	0.0	0.0	0.1 (0.003)	0.0	355	9.87
Businesses	1,118	0.3	7.0	6.3	241.0 (6.79)	17.9	6,244	34.52
Commercial uses	13,646	4.0	6.0	5.4	160.6 (4.52)	11.9	443	26.57
Religious institutions	1,981	0.6	0.6	0.5	11.5 (0.32)	0.9	295	19.65
Industry	598	0.2	3.8	3.4	68.7 (1.94)	5.1	6,327	18.16
Agriculture	3,942	1.2	1.3	1.2	19.0 (0.54)	1.4	329	14.67
Total potable water	341,620	99.9	95.9	86.1	1,288.4 (36.29)	95.5	281	13.44
Total non-treated water	332	0.1	15.4	13.9	60.3 (1.7)	4.5	46,449	3.91
Total	341,952	100.0	111.3	100.0	1,348.7 (37.99)	100.0	325	12.12

Source: Statistics Mauritius (2014)

Water tariffs for the different groups of consumers are shown in Tables 20 and 21.

Table 20: Domestic Monthly Tarrif for Potable Water, 2013

Tariff Bracket	MUR (USD)
Minimum charge (up to 10m ³)	45 (1.27)
Next 10 m ³	8 (0.23) per m ³
Next 10 m ³	10 (0.28) per m ³
Next 30 m ³	17 (0.48) per m ³
Every additional m ³	32 (0.9) per m ³

CWA (2014)

The fixed monthly minimum charge is MUR 45 (USD 1.27). This is a fixed fee for the first 10 m³, irrespective of how much is used. Any additional usage (above 10 m³ per month) is charged per cubic meter. The tariff structure is not proportional to the amount of water consumed, but increases in increments. For example, every cubic meter between 30 and 59 m³ costs MUR 17 and every additional cubic meter above that costs MUR 32.

Table 21: Non-Domestic Monthly Tarrifs for Potable Water, 2014

Non-domestic	Tariff 14	Tariff 15 & 18	Tariff 16	Tariff 17
Minimum charges MUR (USD)	1,122 (31.61)	391 (11.01)	450 (12.68)	220 (6.2)
All cubic meters MUR (USD)	34 (0.96)	23 (0.65)	18 (0.51)	11 (0.31)
	Tariff 53			
Minimum charge MUR (USD)	60 (1.69)			
First 10 m ³ MUR (USD)	6 (0.17)			
Next 10 m ³ MUR (USD)	8 (0.23)			
Next 30 m ³ MUR (USD)	17 (0.48)			

Source: CWA (2014)

Table 21 shows the tariffs for the non-domestic sector. In fact, there are five different tariff structures according to the various types of businesses (commercial, industrial, etc.). Minimum charges apply to all the different tarrifs. For tarrifs 14 to 18, consumption is charged per cubic meter at a fixed rate; Tarrif 53 is based on an incremental scale.

3.3 Modeling Residential Water Consumption

According to Colby (1989), the economic value of water in the residential sector is determined by the willingness to pay and consumer surplus. This approach is useful when a demand curve for water can be estimated. Domestic water usually shows an inelastic demand function because it has no substitutes for basic uses, and water bills usually represent a small proportion of income (Arbues et al., 2003). This section models the demand for residential water, based on theoretical underpinnings involving price and income as determinants.

Theoretical Modeling

The theoretical modeling is based on a non-linear demand function. Suppose the quantity of residential water consumed at time t is given by $WRES_t$ and the average price in the same period is given by $PRES_t$. The inverse demand function is therefore given by:

$$WRES_t = aPRES_t^b \quad (1)$$

The demand function can also be written in logarithmic form such that:

$$\ln WRES_t = a' - b' \ln PRES_t \quad (2)$$

In the above case, b' is the price elasticity of demand for water.

The above can be extended to include income such that:

$$\ln WRES_t = a' - b' \ln PRES_t + c \ln RGDP_t \quad (3)$$

$RGDP$ is the real income per capita.

Econometric Modeling

Using equation 3, the econometric model to estimate the demand function takes the following form:

$$\ln WRES_t = a' - b' \ln PRES_t + c' \ln RGDP_t + \varepsilon_t \quad (4)$$

Where ε_t is an error term.

The above demand function is referred to as the long-run demand function. In fact, in many cases, economic variables are non-stationary. In such cases, a co-integration test is performed to test whether the error term is stationary and whether a long-run relationship may indeed exist. When variables are co-integrated, an error correction model can be estimated. This can take the following forms:

$$\Delta \ln WRES_t = d - e \Delta \ln PRES_t + g \Delta \ln RGDP_t - \lambda(\varepsilon_{t-1}) \quad (5)$$

and

$$\varepsilon_{t-1} = \ln WRES_{t-1} - a' + b' \ln PRES_{t-1} - c \ln RGDP_{t-1}$$

Data

Figure 6 shows the demand for consumption of water in the residential sector. Data was obtained from CWA annual reports, the Digest of Energy and Water Statistics and the Annual

Digest of Statistics. A closer examination of the trend in water consumption shows that there is a steep fall in water demand when there is a change in tariff.

Figure 8: Demand for Water Consumption in the Residential Sector

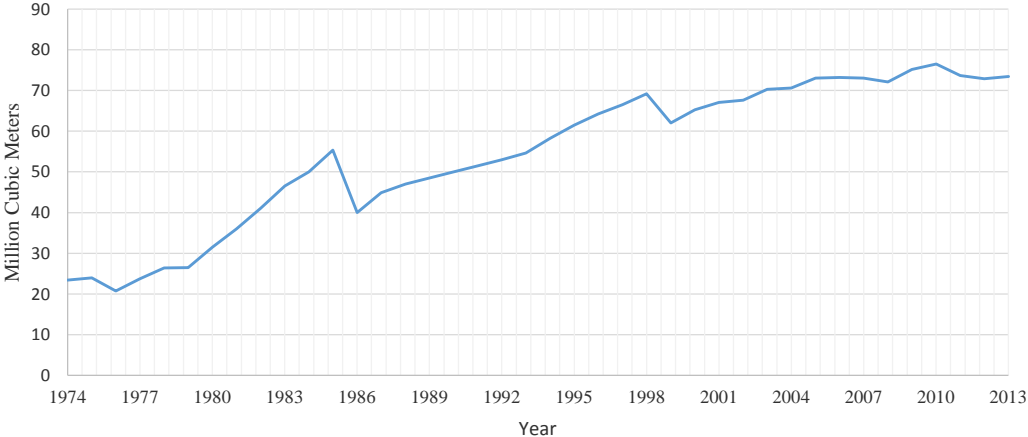

Source: Author’s own calculation from CWA annual reports, Digest of Energy and Water Statistics

Econometric Result

The econometric analysis starts with a unit root test of the two variables. Table 22 shows the results.

Table 22: Unit Root Test of Variables

Level form	ADF statistics	95% critical value	First difference	ADF statistics	95% critical value
$\ln WRES_t$	-3.135(1)	-2.947			
$\ln PRES_t$	3.306(1)	-2.947			
$\ln RGDP_t$	0.276(1)	-2.947	$\Delta \ln RGDP_t$	-3.759	-3.543

The optimal lag length is shown in brackets according to Schwarz-Bayesian information criterion
 Source: author’s calculation

Given the mixture of variables which are stationary at level and first difference, the ARDL is used. The error correction model is shown in Table 23. As can be observed, the coefficient of the price variable is negative and statistically significant, implying that demand is inversely related to price. This is an important validity test of the estimated demand function. The co-integration bounds test is used to test the long-run relationship.

Table 23: Results for Demand for Water for Residential Purposes

Constant	2.162(0.437)***
$\Delta \ln PRES_t$	-0.102(0.050)**
$\Delta \ln RGDP_t$	0.148(0.051)***
λ_{t-1}	0.657(0.150)***
R-bar square	0.407
F(3, 38)	8.098***

*, **, *** represent statistically significant at 10, 5 and 1 percent, respectively
Source: author's calculation

The long-run estimates are provided in table 24. Water is price inelastic in both the short and the long run. In the short run, price elasticity of demand is -0.10 while in the long run it is -0.16. Madhoo (2009); using a linear expenditure system estimates price elasticity to be in the range of -0.06 to -0.26. The estimates in this study are therefore consistent with previous studies.

Table 24: Long-run Demand Function for Water in Mauritius

Long-run Demand Function for water	
constant	3.289(0.323)***
$\ln PRES_t$	-0.155(-0.082)*
$\ln RGDP_t$	0.225(0.044)***

*, **, *** represent statistically significant at 10, 5 and 1%, respectively
Source: author's calculation

Income elasticities in this study are 0.15 and 0.23 in the short and the long run, respectively. Again, these estimates are consistent with Madhoo (2009), who shows that income elasticity lies in the range of 0.27 to 0.68.

Following Kling (1989), the coefficients from the demand function are used to calculate the consumer surplus. The cost paid by a consumer is estimated using the charge by volume. A graphical representation is provided in Figure 9.

Figure 9: Consumer Surplus in Mauritius

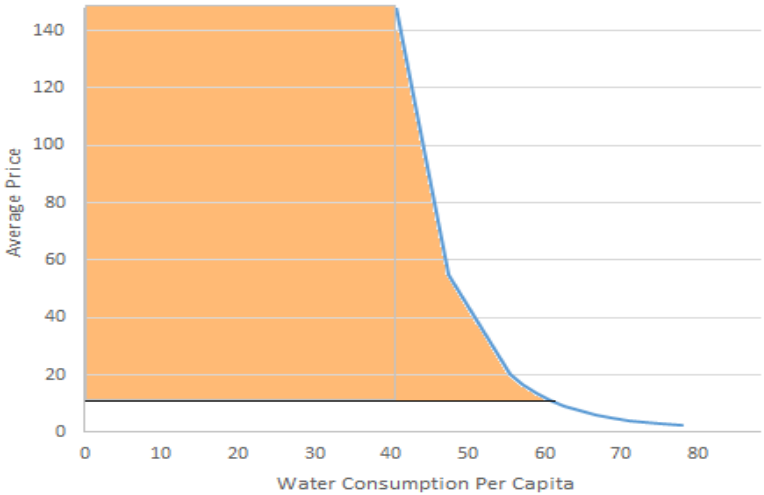

Source: author

The welfare of water is calculated for the range above 40 million m³ because of the logarithmic formulation of the demand function. Using the above estimates, the average consumer surplus per m³ is estimated at MUR 200 (USD 5.63), while the marginal value of water is estimated at MUR 9.91 (USD 0.28) per m³. The total consumer surplus is estimated at MUR 697.3 million (USD 19.64 million).

3.4 Modeling the Demand for the non-Residential Sector: Marginal Productivity of Water

Water demand can be distinguished according to its consumption. Common uses are residential, agricultural, commercial, industrial and recreational. The agricultural demand usually refers to water for irrigation and livestock purposes, while commercial use consists of water used by warehouses, stores and shopping centers, restaurants, hotels and related activities, cinemas and offices, among others. Industrial water demand focuses on uses such as cooling, processing and manufacturing operations, and power generation. Finally, recreational and environmental uses of water make up the remaining non-residential and non-industrial uses that generate a value for the consumer (Worthington, 2011). The interest in estimating demand for water and its price elasticity in the non-residential sector has been growing among scholars, but to date, very few of these studies have been conducted (Worthington, 2011).

The estimation of the value of water in the non-residential sector is based on the neoclassical economics of production. In the manufacturing and commercial sectors, the demand for water is derived, along with other inputs, as part of a production function. Thus, it is not only price that affects the demand for water but also the firm’s output and other inputs used.

This section calculates the economic value of water in the non-residential sector, namely the manufacturing sector, the commercial sector and the tourism sector, using the marginal

productivity approach (Wang and Lall, 2002; Ku and Yoo 2012). To explain the theoretical foundation, a production function is considered as follows:

$$Q = f(K, L, W) \quad (6)$$

Where Q , K , L , and W are output, capital, labor and water consumption. A Cobb-Douglas production function can be written as follows:

$$\ln Q = \ln A + \alpha_1 \ln L + \alpha_2 \ln K + \alpha_3 \ln W \quad (7)$$

The elasticity of production for each factor of production is calculated by taking the partial derivative of the output with respect to the factor under consideration. Thus, for water the elasticity can be expressed as follows:

$$\varepsilon_{CD} = \frac{\partial Q / Q}{\partial W / W} = \alpha_2 \quad (8)$$

The marginal productivity of water is then

$$\rho_{CD} = \varepsilon_{CD} \cdot \left(\frac{Q}{W} \right) \quad (9)$$

Assuming a trans-log function, the production function can be estimated as follows:

$$\begin{aligned} \ln Q = \ln A + \alpha_1 \ln K + \alpha_2 \ln L + \alpha_3 \ln W \\ + \alpha_4 (\ln K)^2 + \alpha_5 (\ln L)^2 + \alpha_6 (\ln W)^2 + \alpha_7 \ln K \ln L \\ + \alpha_8 \ln K \ln W + \alpha_9 \ln L \ln W + \sum_i^n DUM_i Water_1 \end{aligned} \quad (10)$$

The elasticity of water is given by:

$$\varepsilon_{TL} = \frac{\partial Q / Q}{\partial W / W} = \alpha_3 + 2\alpha_6 \ln W + \alpha_8 \ln K + \alpha_9 \ln W \quad (11)$$

The marginal productivity of water is given by:

$$\rho_{TL} = \varepsilon_{TL} \cdot \left(\frac{Q}{W} \right) \quad (12)$$

$DUM_i Water_1$ takes one if the sector is i , for n different economic sectors and zero otherwise.

Data from the Census of Economic Activities from the Statistics Office has been used to estimate the regression. The dependent variable is the total output in thousands of MUR. Water is shown in m³. Capital is the net book value at the end of the period.

Table 25: Regression Analysis of the Marginal Value of Water

Variables	Coefficient	Coefficient
<i>ln K</i>	0.289(0.023)***	0.316(0.086)***
<i>ln L</i>	0.357(0.039)***	-0.129(0.152)
<i>ln W</i>	0.422(0.026)***	0.821(.061)***
$(\ln K)^2$		0.001(0.008)
$(\ln L)^2$		0.001(0.029)
$(\ln W)^2$		-0.017(0.008)**
<i>ln K ln L</i>		0.043(0.018)**
<i>ln K ln W</i>		-0.031(0.015)*
<i>ln L ln W</i>		0.021(0.033)
D – FOOD	0.005(0.010)	0.025(0.010)**
D- TEXTILE	-0.079(0.008)***	-0.077(0.008)***
D-PAPER	-0.022(0.012)*	-0.022(0.012)*
D-CHEMICAL	0.053(0.014)***	0.064(0.015)***
D-RUBBER	0.030(0.013)**	0.039(0.014)***
D-NON METAL	-0.045(0.017)***	-0.011(0.016)
D-METAL	0.035(0.014)**	0.041(0.014)***
D-ELECTRICITY	0.075(0.010)***	0.077(0.022)***
D-CONSTRUCTION	0.053(0.029)*	0.044(0.019)**
D-TOURISM	-0.093(0.012)***	-0.069(0.013)***
D-WHOLESALE TRADE	-0.005(0.010)	-0.007(0.010)
Constant	3.350(0.129)***	2.827(0.278)***
N	1191	1170
F(14,1176)	364.04	354.30
Prob>F	0.0000	0.0000
R-square	0.84	0.85

*, **, *** represent statistically significant at 10, 5 and 1 percent, respectively

Source: Author's own calculations

Table 25 shows the regression results. The R-square is 0.85 implying that the variables contribute to significant variation in output. The first column shows a regression analysis corresponding to the Cobb-Douglas production function and the second one shows the trans-log production function. The difference lies in the number of observations that correspond to missing variables in the calculation.

Table 26: Trans-log Production Function

	Output elasticity of water	Marginal productivity of water MUR (USD)/m ³	Price elasticity
Food	0.08	195 (5.49)	-0.89
Textile	0.02	20 (0.56)	-0.33
Paper	0.35	536 (15.1)	-1.33
Chemical	0.41	1,501 (42.28)	-1.49
Rubber	0.43	1,479 (41.66)	-1.54
Non-metal	0.27	357 (10.06)	-1.17
Metal	0.41	1,288 (36.28)	-1.59
Electricity	0.54	1,938 (54.59)	-1.93
Construction	0.47	3,666 (103.27)	-1.75
Tourism	0.21	160 (4.51)	-1.14
Wholesale trade	0.42	1,784 (50.25)	-1.60
Average	0.32	1,413 (39.8)	-1.34

Source: Author's own estimates from the regression analysis

Table 26 shows the output elasticity, marginal productivity of water and price elasticity of water at the sector level. The output elasticity ranges from 0.02 to 0.54. The marginal productivity of water ranges from MUR 20 (USD 0.56) to MUR 3,666 (USD 103.27) per m³, with an average of MUR 1,413 (USD 39.8) per million m³. The cross-section econometric test shows that for most of the economic sectors, water demand is price elastic. The contribution of water is significant for the electricity, construction, metal, chemical and rubber industries.

The high price elasticity of water is attributed to the fact that economic sectors are also able to exploit surface water directly through rivers. A word of caution is important in interpreting the data. Missing variables on other intermediate products may inflate the marginal value of water.

3.5 Scenario-based Analysis of Water Use and Water Abstraction

Forecast of water demand from 2015 to 2030

This section attempts to forecast residential and non-residential water demand for the period between 2015 and 2030 using a time-series econometric analysis. The analysis considers residential demand for water and non-residential demand separately. Non-residential demand includes industrial, business and government demand for water. The determinants for residential demand are real average price, total income and population. An ARDL is used with a long-run specification and an error correction model (ECM). The two econometric equations are shown below:

Residential demand

$$\text{Long run: } \ln TWRES_t = -\beta_0 \ln PRES_t + \beta_1 \ln TRGDP_t + \beta_2 \ln POP_t + \varepsilon_{res} \quad (13)$$

$$\text{ECM: } \Delta \ln TWRES_t = \eta_0 - \eta_1 \Delta \ln PRES_t + \eta_2 \Delta \ln TRGDP_t + \eta_3 \Delta \ln POP_t - \phi(\varepsilon_{t-1}) \quad (14)$$

$TWRES_t$ is total demand for residential water

$TRGDP_t$ is total income at time t

$PRES_t$ real price of water at time t

POP_t is population at time t

Non-residential demand including government

$$\text{Long run: } \ln TWNRES_t = -\chi_0 \ln PNRES_t + \chi_1 \ln TRGDP_t + \varepsilon_{nres} \quad (15)$$

$$\text{ECM: } \Delta \ln TWRES_t = \nu_0 - \nu_1 \Delta \ln PRES_t + \nu_2 \Delta \ln TRGDP_t - \tau(\varepsilon_{nrest-1}) \quad (16)$$

Table 27 shows the ECM for residential water demand. All the coefficients have the expected sign – in other words, negative for average price, positive for income and population. The short-run price elasticity is estimated at -0.12 while the long-run price elasticity is -0.17. The short-run and long-run income elasticities are 0.21 and 0.30, respectively.

Table 27: Error Correction Model for Domestic Water Consumption

Variable	Coefficients
$\Delta \ln TRGDP_t$	0.206(0.0593)***
$\Delta \ln POP_t$	7.544(3.994)*
λ_{t-1}	-0.680(0.145)***
Long-run coefficient	
$\ln PRES_t$	-0.173(0.078)**
$\ln TRGDP_t$	0.303(0.048)***
R-bar square	0.432
F(3, 29)	9.4406***

*, **, *** represent statistically significant at 10, 5 and 1 percent, respectively

Source: Author's own calculations

Table 28 provides the regression results for non-domestic consumption. Again, the coefficients have the expected sign. The price elasticities in both the short and the long run are higher than those for residential water demand, namely equal to -0.63 and 0.72 respectively. Income elasticity is also higher at 0.39 in the long run and 0.22 in the short-run.

Table 28: Error Correction Mode for non-Domestic Water Consumption

Variables	Coefficient
$\Delta \ln PNRES_t$	-0.627(0.101)***
$\Delta \ln TRGDP_t$	0.224(0.063)***
CONS	1.143(0.985)
λ_{t-1}	-0.570(0.100)***
Long-run coefficients	
$\ln PNRES_t$	0.717(0.161)***
$\ln TRGDP_t$	0.393(0.059)***
Cons	2.012(1.084)
R-bar square	0.481
F(3, 29)	9.4406***

*, **, *** represent statistically significant at 10, 5 and 1%, respectively

Source: Author’s estimates from regression analysis

Using the ARDL estimates, we forecast the demand for water for the years 2015 to 2030. Figures 10 and 11 show the results. Three scenarios are estimated, related to economic growth rates of of 2, 5.5 and 7 percent.

Figure 10: Forecast of Demand for Residential Water, 2016-2030

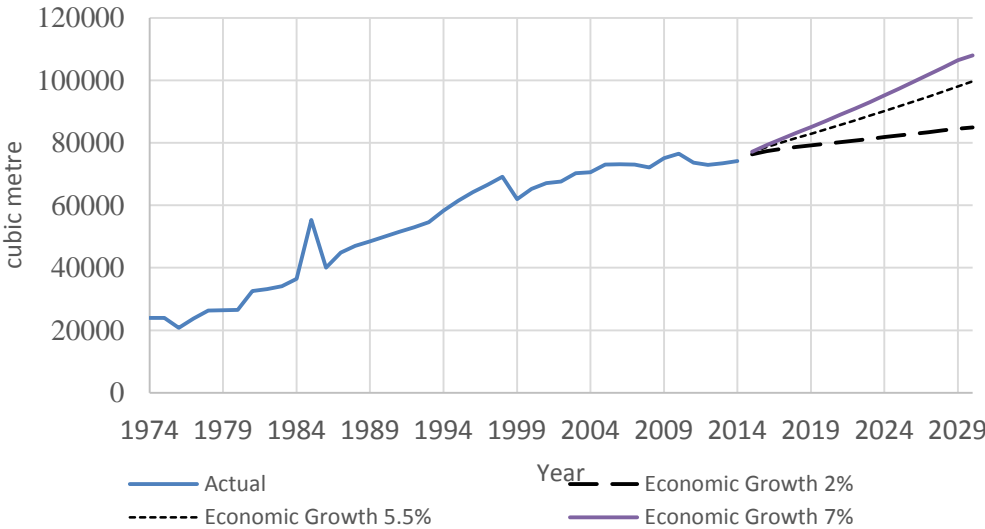
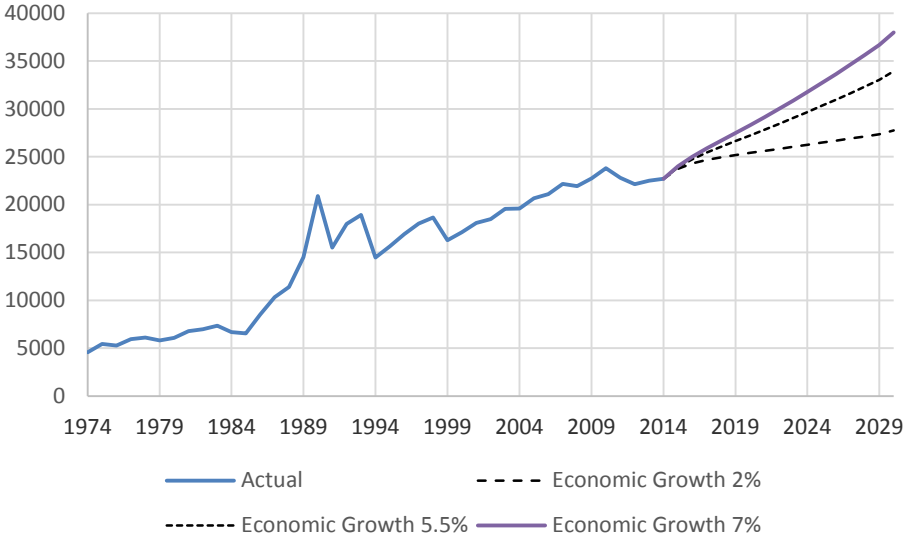

Figure 11: Forecast of Demand in the non-Residential and Government Sectors, 2015-2030



A summary of the forecast for 2030 is shown in Table 29. The percentage increase from the 2014 water level is given in brackets. As expected, the 2 percent growth rate provides the lowest increase – 14.5 percent for the domestic sector and 27.7 percent for the non-domestic sector. The increase is higher for a 5.5 percent economic growth rate and highest for the 7 percent growth rate.

Table 29: Residential and non-Residential Demand for Water in 2030

	Actual	Economic growth 2%	Economic Growth 5.5%	Economic Growth 7%
Household consumption (million m ³)	73.4	85.0 (14.5)	99.7 (34.4)	108.0 (45.6)
Non-domestic (including government) (million m ³)	22.3	27.7 (22.2)	34.0 (49.6)	38.0 (67.4)
Total (million m ²)	95.7	112.7 (16.3)	133.7 (38.0)	146.0 (50.7)

Source: Author’s own estimates

Figure 12 shows the aggregate demand for water under the three economic growth scenarios. The total demand for water in 2030 is estimated at 113 million m³, 134 million m³, and 146 million m³, under the 2, 5.5 and 7 percent economic growth scenarios, respectively.

Figure 12: Aggregate Demand for Water in 2030 Under Different Economic Growth Scenarios

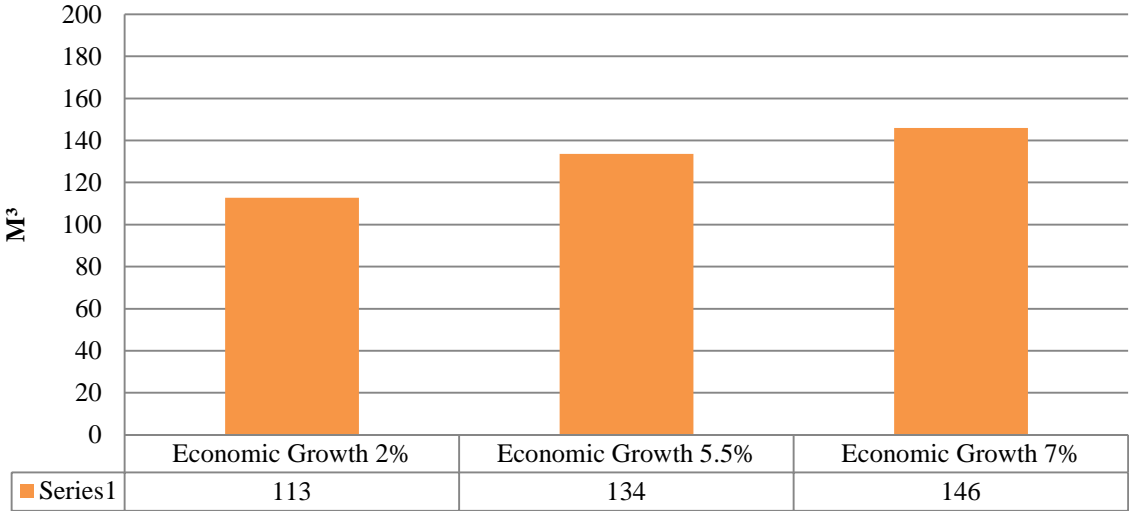

Source: Author’s own estimates

3.6 Water Abstraction Under Climate Change Scenarios

Water abstraction is dependent on the amount of precipitation, which, in turn, is likely to be affected by climate change. The impact of climate change on precipitation is estimated using different scenarios or storylines developed by the IPCC (2000). McSweeney et al. (2010) work out the expected impacts of these climate change scenarios for Mauritius using three storylines: A2, A1B and B1.

The A1 scenario family describes a future world of very rapid economic growth, with a global population that peaks mid-century and declines thereafter. It involves the rapid introduction of new and more efficient technologies, and assumes convergence among regions, capacity building, and increased cultural and social interactions, with a substantial reduction in regional differences in per capita income. The A1 scenario family develops into three groups that describe alternative directions of technological change in the energy system. The three A1 groups are distinguished by their technological emphasis: fossil intensive (A1FI), non-fossil energy sources (A1T) or a balance across all sources (A1B). ‘Balanced’ is defined as not relying too heavily on one particular energy source. The underlying assumption is that similar improvement rates apply to all energy supply and end-use technologies.

The A2 storyline describes self-reliance and the preservation of local identities, with fertility patterns across regions converging very slowly. Economic development is primarily regionally oriented and per capita economic growth and technological change are more fragmented and slower than in other storylines.

The B1 storyline and scenario family describes a convergent world with a global population that peaks mid-century and declines thereafter, as in the A1 storyline, but the emphasis is on global solutions to economic, social and environmental sustainability, including improved equity, but without additional climate initiatives.

The impact of climate change on precipitation by 2030 is shown in table 30. Only the maximum and minimum is provided.

Table 30: Climate Change Scenarios for Rainfall by 2030 (A2, A1B and B1)

Climate change scenarios (% change in rainfall)						
	A2		A1B		B1	
	Minimum	Maximum	Minimum	Maximum	Minimum	Maximum
Annual	-9	14	-12	12	-3	3
Summer	-10.8	21.5	-17.3	17.5	-11.8	10.8
Winter	-18.2	14.5	-21.7	12.5	-21.2	8.2

Source: McSweeney et al. (2010)

Based on the above predictions, we estimate water abstraction by the water supply industry for the worst of the different climate change scenarios. Choosing the worst case scenario makes sense since the storage system should be prepared for this scenario in order to guarantee a sustainable provision of water. Estimating the impact of climate change on water storage can be done using highly sophisticated modeling tools. However, this is beyond the scope of this study. We perform a simple analysis, applying the percentage change to the average rainfall over the last 10 years. This is shown in Figure 13. An annual total of 188 million m³ is abstracted under the A2 scenario and 177 million m³ under the A1B scenario . Accounting for the rate of Non-Revenue Water, and assuming the leakage rate and the rate of commercial losses are constant, Figure 13 also shows the amount of potable water that is available for distribution to the residential, economic and government sectors.

Figure 13: Total Water Production Under Climate Change Scenarios in 2030 (millions m³)

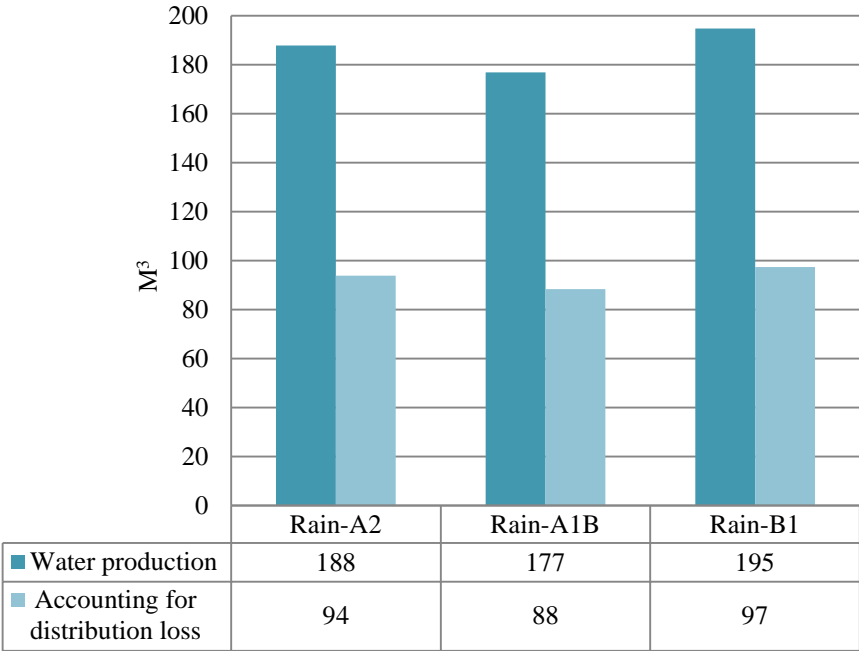

Source: Author’s own calculation

We have three climate change scenarios – A2, A1B and B1 – and three economic growth scenarios. By combining these, nine different scenarios for water abstraction can be constructed. The water shortages to be expected under these various scenarios are depicted in Figure 14.

Figure 14: Water Shortages Under Different Climate Change and Economic Growth Scenarios (millions m³)

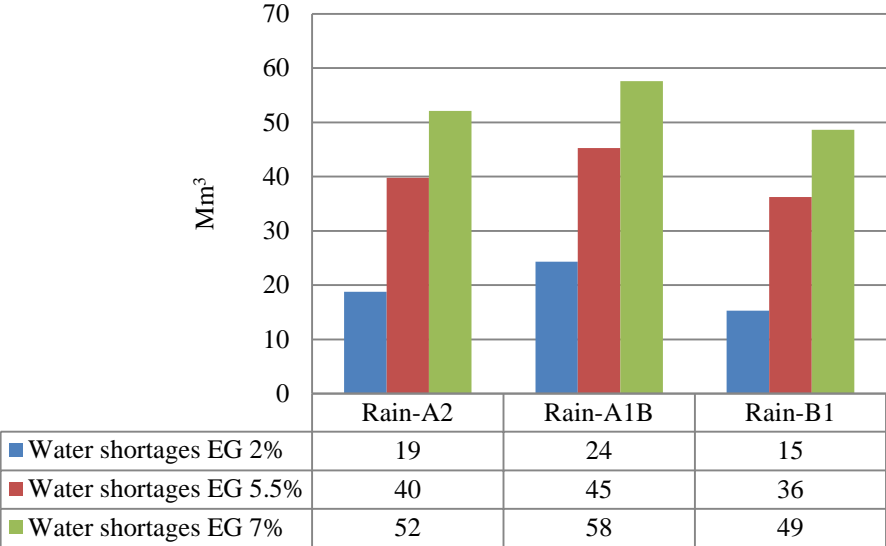

Source: Author’s own estimate

Figure 14 shows the shortages of water which are expected to prevail in 2030 with the current storage system. With the rise in demand for water and the impact of climate change, shortages of water range from 15 million m³ to 58 million m³ annually. Under A2, water shortages will be in the range of 19 million m³ to 52 million m³, corresponding to an economic growth of 2 percent and 7 percent, respectively. Similarly, under A1B, the water shortages are computed to be between 24 million m³ and 58 million m³; and under B1, the shortages will lie somewhere between 15 million m³ and 49 million m³. With an economic growth of 5.5 percent, the shortages range from 36 million m³ to 45 million m³ (B1 and A1B respectively).

3.7. Behavior of Households Toward Water Shortages: Evidence From the Water Use Survey

It was deemed important to understand the behavior of households as far as water is concerned. As mentioned earlier in the report, the economic sustainability of water is a serious issue, particularly in terms of financing water storage systems or repairing pipe networks. With this in mind, a ‘Household Water Use Survey’ was undertaken between October 2015 and November 2015, to analyze the impacts of water tariffs and water shortages at the household level. A questionnaire was prepared and administered to 375 respondents through face-to-face interviews. The island was divided into five regions and respondents were chosen according to region. Sample areas were selected randomly and in

each area around 15 locations were identified. Within these locations, random streets were selected and eventually interviewers were requested to select predetermined households – in other words, every nth house.

Expenditure on water at the household level

The first results relate to expenditure on water at the household level (Table 31). The average water bill stands at MUR 177.

Table 31: Indicators on Water from the Survey

Indicators	Averages
Household income per month	MUR 23778.4 (USD 700)
Water bill per month	MUR 177.3 (USD 5.2)
Household size	3.53

From this, the share of the water bill in household income can be calculated. The average household income stands at MUR 23,778 and the average water bill is MUR 177. This means that the average water bill is 0.7 percent of the average household income. However, this ratio varies with changes in income, as can be seen in Table 32.

Table 32: Ratio of Water Bill to Monthly Household Income

Household Income (MUR)	Water bill as % of household Income
5001 - 7000	1.92
7001 - 9000	1.739
9001 - 12000	1.347
12001 - 15000	1.175
15001 - 20000	0.942
20001 - 25000	0.84
25001 - 30000	0.707
30001 - 35000	0.602
35001 - 40000	0.56
40001 - 45000	0.472
45001 - 50000	0.48
50001 - 55000	0.413
55001 - 60000	0.358
60001 - 70000	0.35

Table 32 shows that for households in the 5001-7000 income bracket, their water bill is a relatively higher proportion of their income (1.92 percent). As income rises, the ratio

declines (0.35 percent for those earning between MUR 60,001-Rs70,000 per month). A graphical illustration is provided in Figure 15.

Figure 15: Ratio of Water Bill to Monthly Household Income

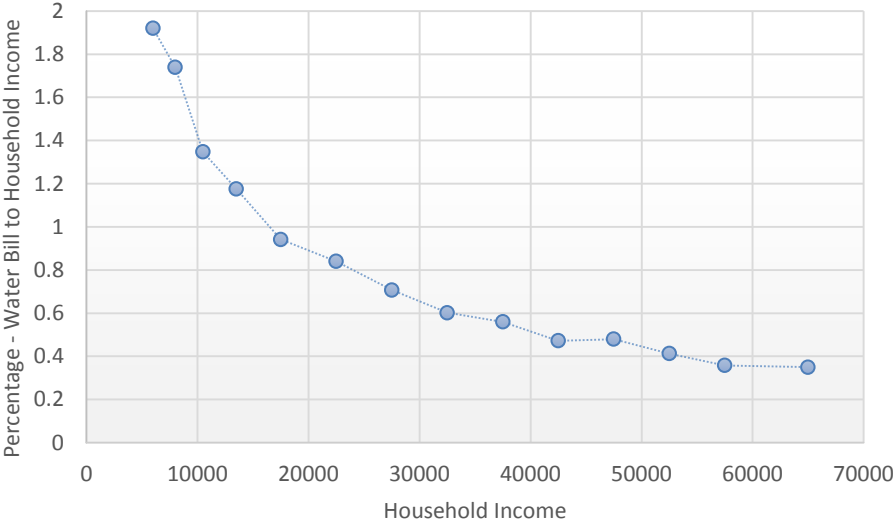

The results show that households in the lower income bracket pay a higher share and that, therefore, the water tariff is highly regressive. To analyse the regressive nature of the water tariff we conducted a regression analysis to control for household size. The results are shown in Table 33.

Table 33: Relationship between Share of Water Bill, Household Income and Household Size

Constant	1.200 (0.0363)***
Household income	-0009(0004)***
Household size	0.0185(0.009)**
R-bar square	0.07
F(2, 372)	263.03

*, **, *** represent statistically significant at 10, 5 and 1 percent, respectively
 Source: Author’s own calculation from Household Survey

Controlling for household size, the regression analysis still shows a negative relationship between the share of the water bill and household income. A positive relationship, as expected, is observed for the variable household size.

Impacts of water scarcity

One of the impacts of water scarcity is that households installed water tanks to ensure a constant supply of water. The survey reveals that 43.4 percent of respondents own a water tank. Table 3 shows a logit regression explaining the relationship between water tanks and household income. As expected, household with higher incomes are more likely to install a water tank. We include two additional variables in the regression as controls, household size and age. The latter is statistically significant but the former is not.

Table 34: Logit Regression – Water Tank and Household Income

Constant	-0.624(0.072)***
Household income	0.023(0.001)***
Household size	0.009(0.023)
Age	0.008(0.001)***
Pseudo R-bar square	0.035
Log-pseudolikelihood	-4216.980

*, **, *** represent statistically significant at 10, 5, and 1 percent, respectively

Source: Author's own calculations from Household Survey

The survey also reveals that around 13.44 percent have installed a water pump because of lower pressure.

Conclusion

The forecasting exercise concludes that Mauritius may be heading toward a water crisis if appropriate water management strategies are not adopted. The results from the water accounts, the analysis of the economic value of water, and the scenario-based forecast of water shortages, provide the basis for designing water policies and strategies. A summary of findings is provided in Section 3 together with policy implications.

This section (Section 1) analyzes the current and future situation of the Mauritian water sector using water accounts and a demand and supply analysis. Parts 2.10 and 2.11 show that during recent years, and at certain times of the year and in specific regions, Mauritius is already facing situations of water scarcity. All other things being equal, this is likely to be exacerbated by climate change.

A typical answer to these challenges is to look for supply-side driven solutions – namely, to increase storage capacity and work on the physical and commercial distribution losses (i.e., reduce the amount of Non-Revenue Water). The following section (Section 2), proposes an alternative solution to the challenges facing the Mauritian water sector. It argues that water sector performance can be improved if specific governance issues are addressed. To this end, Section 2 analyses the Mauritian water sector from a governance perspective. It will provide an in-depth analysis of the institutional setting of Mauritian water sector governance and then discuss specific problems, in order to deduce a number of policy recommendations to enhance governance and thereby the performance of the Mauritian water sector. These recommendations will be summarized in Section 3 of this study.

References

Arbués, F., Garcia-Valiñas, M. A. and Martínez-Espiñeira, R. (2003). Estimation of residential water demand: a state-of-the-art review. *Journal of Socio-Economics*, vol. 32, pp.81-102.

CWA (2014). Annual Report. Central Water Authority. CWA Head Office, Royal Road, St Paul.

Colby, B. G. (1989). Estimating the Value of Water in Alternative Uses. *Natural Resources Journal*, vol.29, pp. 511-527.

Hassan, R. M. and Farolfi, S. (2005). Water value, resource rent recovery and economic welfare cost of environmental protection: a water-sector model for the Steelpoort sub-basin in South Africa. *Water SA*, vol. 31, no.1, pp.9-16.

ICWE (1992). The Dublin Statement and report of the conference. International conference on water and the environment: development issues for the 21st century. 26-31 January. Dublin.

IPCC (2000) IPCC Special Report Emissions Scenarios Summary for Policy Makers. Intergovernmental Panel on Climate Change. ISBN: 92-9169-113-5.

Kling, C. L. (1989). The Importance of Functional Form in the Estimation of Welfare. *Western Journal of Agricultural Economics*, ol.14, no.1, pp.168-174.

Ku, S-J, and Yoo, S-H. (2012). Economic Value of Water in the Korean Manufacturing Industry. *Water Resource Management*, vol. 29, pp.81-88.

Lange, G. M. and Hassan, R. (2006). Introduction to water issues and water accounting in Southern Africa. *The Economics of Water Management in Southern Africa – An Environmental Accounting Approach*.

Lange, G-M., Mungatana, E., and Hassan, R. (2007). Water Accounting for the Orange River Basin: an economic perspective on managing a transboundary resource. *Ecological Economics*, vol.61, pp. 660-670.

Madhoo, Y. N. (2009) Policy and nonpolicy determinants of progressivity of block residential water rates - a case study of Mauritius. *Applied Economics Letters*, vol.16(2), pp.211-215.

McSweeney, C., New, M. and Lizcano, G. (2010). UNDP Climate Change Country Profiles: Mauritius. Available: <http://country-profiles.geog.ox.ac.uk/> [Accessed 10 May 2013].

Moran, D and Dunn, S. (2008). The economic value of water use: Implications for Implementing the Water Framework Directive in Scotland. *Journal of Environmental Management*, Vol. 87, pp.484-496.

Rogers, P., de Silva, R., and Bhatia, R. (2002). Water is an economic good: How to use prices to promote equity, efficiency, and sustainability. *Water Policy*, vol.4, pp. 1-17.

Savenije, H. H. G. (2002). Why water is not an ordinary economic good, or why the girl is special. *Physics and Chemistry of the Earth, Parts A/B/C*. Vol.27, No.11-22, pp.741-744.

Statistics Mauritius (2014) Digestion of Energy and Water. Ministry of Finance and Economics Development. Republic Of Mauritius.

Turner, K., S. Georgiou, R. Clark, and Brouwer, R. (2004). Economic Valuation of Water Resources: from the Sectoral to a Functional Perspective of Natural Resource Management. Rome: FAO.

Wang, H. and Lall, S. (2002). Valuing water for Chinese industries: a marginal productivity analysis. *Applied Economics*, vol. 34 (6), pp.759-765.

Worthington, A. C. (2011). Commercial and industrial water demand estimation: Theoretical and methodological guidelines for applied economics research. Discussion Papers Economics, Griffith Business School ISSN 1837-7750.

SECTION TWO: WATER GOVERNANCE

Chapter 4: The Institutional Setting of Mauritian Water Sector Governance: What Place for Sustainability?

Aleksandra Peeroo

Introduction

The previous chapters of this report analyzed the current water status in Mauritius and highlighted the fact that, at certain times of year (during the winter and the beginning of summer) and in certain regions, water supply barely meets demand. Furthermore, the scenario-based analysis shows that these tensions are likely to be exacerbated in future as a result of climate change. According to estimates by the Mauritius Meteorological Services, published on the website of the Ministry of Environment, rainfall is set to decrease by 8 percent and usable water resources by 13 percent, by 2050.¹² In addition, according to the United Nations, Mauritius is already facing a situation of water stress which will lead to water scarcity by 2020 (National Economic and Social Council, 2014, p. 11). This is supported by findings in the previous chapters.

However, water stakeholders in Mauritius seem to agree on the fact that Mauritius is a water rich country. Even though rainfall is becoming more erratic, there should be enough water available to meet demand. So why the concerns over water scarcity? A recent OECD report explains that the water crisis is largely a crisis of governance (OECD, 2011, p. 17). This means that, even if water is available in sufficient quantities, the mismanagement of water resources will lead to a situation where there is not enough water available for the different water uses. Therefore, we need to examine whether water sector governance – the system in place to plan, monitor and direct the water sector – is prepared for such a situation.

Being prepared for a water crisis entails that water sector governance must take the question of sustainability into account. Only sustainable water resources and services will allow Mauritius to meet the demand in the long term. Isnard and Barraqué (2010), distinguish three facets of sustainability that are important for the water sector. Firstly, *economic sustainability*, which entails the capacity of water services to recover their costs, not only for the operation and maintenance of water services, but also for long-term investments (ibid., pp. 4 ff.). Secondly, *environmental sustainability*, which requires that water corresponds to defined safety norms, that the use for water of future generations is guaranteed, and that the quality and quantity of water resources is safeguarded (ibid., p.12). Thirdly, *ethical or social aspects of sustainability*, which means that users are able and willing to pay for the water services received (ibid., p. 18).

It is only when water sector governance addresses these three aspects that we can expect to achieve sustainability for water services.

¹² http://environment.govmu.org/English/Climate_Change/Pages/Climate-Change.aspx (03.05.2015)

This chapter will, therefore, study the institutional setting for water sector governance in Mauritius and identify to what extent sustainability considerations are taken into account. Section 4.1 elaborates on the nature of water sector governance; namely, its close relationship with regulation and the important question of vertical and horizontal decision-making decentralization. Section 4.2 presents a theoretical framework for providing a micro-institutional mapping of governance according to the various tasks and dimensions of water sector governance. Section 4.3 analyzes the respective roles of the different water actors in Mauritius, with particular attention paid to their sustainability considerations. Section 4.4 provides an application of the theoretical framework to the Mauritian case and presents a governance matrix. This matrix depicts the distribution of governance responsibilities among the various water actors. The final section concludes.

4.1 The Nature of Water Sector Governance

Governance generally refers to binding decision-making in the public sphere (Hooghe and Marks, 2003, p. 233). Water sector governance can be understood as the system in place to oversee, plan, direct, monitor and enforce the transactions between the various water uses. It determines the rules and practices for decision-making on water policy and implementation, and involves political, institutional and administrative processes. These processes define how decisions are taken and implemented and how stakeholder interests are reflected (OECD, 2009, p. 2). Therefore, water sector governance comprises questions on how responsibilities and tasks around different dimensions of water resources and drinking and wastewater services are allocated, and how different actions are coordinated.

Because water sector governance concerns the very nature of decision-making in the water sector, it is significant for the success of water resource management and the delivery of drinking and wastewater services. It is, therefore, an important determinant of water sector performance. Problems in the governance of the water sector are at the source of dysfunctions that may translate into indicators illustrating low performance – for example, polluted water resources or high leakage rates of water distribution systems. A coherent system of water sector governance requires a clear distribution of tasks and responsibilities among various water actors. In order to be able to address institutional dysfunctions, the governance of the sector needs to be well understood (Peeroo, 2014, pp. 79, 158). Therefore, the role of information is critical. Information must be relevant, standardized and coherent in order to provide a basis for effective decision-making (*ibid.*, p. 166).

Closely linked to the governance of the water sector, is the question of water sector regulation. Regulation can, in fact, be seen as a subcategory of governance since it also deals with planning, directing, monitoring and enforcing rules related to specific dimensions of the water sector. Regulation in the water sector is unavoidable. From a standard economic approach there are several market failures that call for intervention. First of all, water systems are natural monopolies. The prevention of the abuse of the monopolistic position

motivates regulation.¹³ Secondly, water services imply the possibility of important negative externalities on the environment, on health and on road infrastructures and economic activity (via maintenance and extension works). A third reason for regulation lies in the existence of ‘asymmetric information’¹⁴ – for instance, difficulties in observing the state and condition of underground assets. Furthermore, the evolution of hydrologic and demographic factors is a source of uncertainties. Finally, regulation plays an important role because water is a ‘critical infrastructure’. As Ménard (2009a, pp. 84 ff.) explains, water is essential for a viable society. We need water for our survival, directly, and indirectly through the production of food and (in some cases) for energy. This need for regulation can culminate in the creation of a regulatory agency – although, this is the exception rather than the rule. The Water Services Regulation Authority (OFWAT) for England and Wales is one such example.

Not only is regulation inevitable in the water sector, it also plays an important role in its performance, as Andres et al. (2007) demonstrated in a study of 1,000 privatization and concession contracts in the telecommunication, electricity, water and transportation sectors in Latin America. The study demonstrates how performance measures, such as the quality of services, prices, productivity and the number of renegotiations, are affected by the regulatory and governance framework. Since both governance and regulation are embedded in a specific institutional framework, institutions play a key role in the governance and regulatory performance and should not be left out of the analysis (Peeroo, 2014, p. 41). Shirley and Ménard (2002) present various case studies that corroborate these findings. In a study on corruption, Peeroo (2012) analyzes how the performance of the water sector is lowered by weaknesses in governance. Governance, therefore, is a critical issue in the water sector.

The debate on governance centers around the question of the levels at which it should take place. This question is closely related to the idea of institutional decision-making decentralization. Peeroo (2014, p. 21) defines institutional decision-making decentralization as the “distribution of formal authority to make binding decisions across government bodies”. As such, institutional decentralization has a vertical and a horizontal facet. Vertical institutional decentralization means the involvement of various levels of government – for example, national, regional and local. This has been the focus of the fiscal federalism literature since its inception (ibid., pp. 13 ff.). At the same time, the transaction cost literature has highlighted the multi-actor nature of government, stressing that ‘government’ at any given vertical level is not a unified body but consists of various ministries, agencies, committees and other actors (Estache and Martimort, 1999, pp. 2 ff.). This multi-actor nature of government can be referred to as horizontal decentralization (Peeroo, 2014, pp. 20 f.). The governance and regulatory designs are often vertically and horizontally

¹³ The idea of the necessity to protect monopolistic rents in this neo-classical approach is close to the idea of new institutional economics – that highly specific assets of water systems generate quasi-rents that need to be protected from opportunistic behavior.

¹⁴ Information is said to be asymmetric when one party of an economic transaction holds more information than the other. This information advantage might then be used to the other party’s detriment. The most famous illustration was provided by Nobel Prize winner George Akerlof who showed that information asymmetry can cause the disappearance of certain goods – in his example good quality second hand cars (Akerlof, 1970), but it might also apply to good quality water services.

decentralized, because different parties are involved in the regulation of utilities. Vertically, distinct levels of government can be included in the regulatory process. Some of the regulation might be done at the national level, some at the local. Horizontally, various bodies, such as different ministries, might be responsible for the regulation of a particular aspect, for instance the environmental regulation.

Many different regulatory models exist and they imply significant trade-offs. For example, the potential benefits from a better adaptation to local conditions must be weighed against potential problems arising from the higher number of regulatory entities that this would entail, as well as the difficulties in coordinating these. In the case of Mauritius, one important feature must be kept in mind: Mauritius is a small, insular country. Therefore, institutional decentralization, particularly vertical decentralization, might be a less attractive option. The transaction costs of decentralizing – namely, the costs of coordinating the various levels of government – might be too high.¹⁵

The water sector typically represents a multi-actor setting. There are several reasons for this. First of all, the definition of water sector governance involves a multitude of aspects – planning, monitoring, and other tasks – which require a range of actors. Secondly, the water sector is comprised of different activities related to water resources, raw water distribution, water treatment, distribution of treated water, retail, sewage collection, sewage treatment, sludge treatment, sludge disposal (Maziotis, 2012, p. 2) and, where applicable, storm water control. Thirdly, there are multiple uses of water: domestic, industrial, commercial and public, and therefore a variety of user groups. Finally, water sector governance concerns different responsibilities related to environmental, social or safety aspects. A combination of all these factors helps to explain the multi-actor nature of the water sector and its governance.

By analyzing the extent of decentralization of water sector governance, this study also aims to gain a deeper understanding of how the global institutional setting translates to lower levels. This question has not been entirely explored yet. In order to fully comprehend this topic, Ménard (2009b, p. 40 and 2009c) stresses the importance of micro-institutions, which he defines as “... specific institutions that operate at the local and/or sector level under the umbrella of the general rules of the game established by legal and political institutions and that transform these general rules into operational ones” (Ménard, 2009a, p. 84). Thus, micro-institutions translate the global institutional framework to the micro-level. Peeroo (2014) provides such an analysis for the French and German water sectors. Our analysis of the micro-institutional setting of the governance of the water sector aspires to add to this new strand of literature.

¹⁵ Sobhee (2009, p. 38) also points out that decentralization might not be efficiency enhancing, unlike the predictions of the fiscal federalism literature (Tiebout, 1956; Musgrave, 1959; Oates, 1972 and 1999). He highlights the fact that the institutional setting, in particular its political context, is a very important factor, especially where locally elected parties do not belong to the parties forming the central government. In this case, they might be reluctant to adhere to rules and procedures set by the center.

4.2 A Framework for the Analysis of Water Sector Governance

The framework used to analyze water sector governance is based on the work of Trémolet and Binder (2010), which has been further developed by Peeroo (2014). The framework proposes a matrix that allows identifying how regulatory functions and tasks are distributed among various actors. The identified tasks include the collection of information and data, the definition of rules, the monitoring of the implementation of existing rules, and the enforcement of decisions. To complete the tasks for governance, we also include strategy and planning, which concerns the definition of water policies and the coordination of stakeholders (such as government bodies or different user groups).

Alongside these governance tasks, we identify various dimensions of water sector governance. According to Trémolet and Binder (2010) and Peeroo (2014), these dimensions involve tariffs, service quality, competition, consumer protection, safety, the environment, technical requirements and social considerations.

In this study, we refine this approach to better account for the various aspects of water sector governance. Firstly, we distinguish three broad areas of action; namely, water resources, drinking water services and wastewater services. Secondly, for each of these three areas, we define specific dimensions of water sector governance. For water resources, we take their allocation (access) and quality (environmental considerations) into account. For drinking water services, we consider tariffs, service quality, consumer protection, safety regulation, technical regulation and social regulation. For wastewater services, we highlight environmental regulation, tariffs, technical regulation and social regulation. As a result, the analysis of these dimensions and tasks of water sector governance requires a six-by-twelve matrix with 72 fields, showing the actors participating in the different areas of governance.

The regulation of the quality of services comprises aspects such as water pressure, unaccounted for water, reliability and coverage, but also more specific indicators such as phone waiting times (for customers trying to reach the water operator) or the time taken to resolve a customer's complaint (Marques, 2010, pp. 189 ff.). Consumer protection pertains, primarily, to what happens when consumer complaints are not properly addressed by the operator (*ibid.*, pp. 28 f.). Safety regulation mainly concerns the quality of drinking water and the elimination of health hazards. Environmental regulation involves the protection of water resources and wastewater discharges. Social regulation refers to equity between users and access to water services (*ibid.*, p. 29). Technical regulation, such as the specification of technical requirements for the physical infrastructure, is important given the fact that water infrastructure comprises of large technical systems. Therefore, the regulation of technological aspects of water utilities plays a big role in safety and the environment. A recent strand of literature analyses the need for coherence between institutions and technologies in infrastructure (Finger et al., 2005; Künneke and Finger, 2007; Künneke et al., 2010). Technical regulation in the water sector concerns a variety of aspects – for instance, the interoperability of different infrastructure components (for example, the physical interconnection of the primary and secondary network or, more specifically, the precise

prescriptions on how to fill the space between casing pipes and product pipes¹⁶). Technical regulation also refers to the maintenance and operability of water systems (for example, the ventilation of drinking water pipes¹⁷ or dynamic changes of pressure in water supply systems¹⁸) or the requirements for cold water storage tanks.¹⁹

In order to compile the micro-institutional matrix of water sector governance in Mauritius, it was necessary to collect data on the various water actors and their respective responsibilities. Part of this data was gathered from the literature. To support the validity of this data and, more importantly, to fill in any possible gaps, further data was collected with the help of a survey of the main governance actors (as well as interviews and a workshop). The information collected represents a new and original qualitative data set, which allows us to paint a clear picture of the micro-institutional setting of water sector governance in Mauritius.

The design of the survey draws extensively on the OECD Survey on Water Governance (OECD, 2009) and has been adapted to reflect the situation in Mauritius and address sustainability issues.²⁰ A copy of the survey can be found in Annex B. We were able to collect answers from the eight major public water players in Mauritius: the Ministry of Energy and Public Utilities,²¹ the Central Water Authority, the Wastewater Management Authority, the Water Resources Unit, the Irrigation Authority, the Ministry of Environment, the Ministry of Agroindustry and the Ministry of Health. The next section details their involvement in Mauritian water sector governance.

4.3 Mauritian Actors for Water Sector Governance and Their Sustainability Considerations

Due to the multi-actor nature of the water sector, a variety of ministries, agencies and other bodies are responsible for carrying out the different aspects of water sector governance. What follows is an overview of the main actors and their respective functions in the Mauritian context. Particular attention is paid to the extent to which these actors are aware of sustainability issues in the water sector.

¹⁶ [http://www.dvgw.de/no_cache/angebote-leistungen/regelwerk/regelwerkverzeichnis/?id=28281&tx_dvgwregelwerkverzeichnis\[q\]=w+307](http://www.dvgw.de/no_cache/angebote-leistungen/regelwerk/regelwerkverzeichnis/?id=28281&tx_dvgwregelwerkverzeichnis[q]=w+307) (17.12.2013).

¹⁷ <http://www.dvgw.de/regelwerknews-de/archiv-rw-news/dvgw-regelwerk-newsletter-nr-132007/> (17.12.2013).

¹⁸ <http://www.dvgw.de/regelwerknews-de/archiv-rw-news/dvgw-regelwerknews-nr-608/> (17.12.2013).

¹⁹ <http://publicutilities.govmu.org/English//DOCUMENTS/WATERTANK-SPECS.PDF> (27.04.2015).

²⁰ The original OECD survey is available at <http://oecd.org/governance/regional-policy/44689618.pdf> (31.08.2015).

²¹ The Ministry of Energy and Public Utilities participated in a preliminary version of the survey but was unfortunately the only main water actor not to attend the workshop where governance issues were discussed in detail.

Ministry of Energy and Public Utilities

The Ministry of Energy and Public Utilities (MEPU) is responsible for water and waste water policymaking and legislation.²² On its website, it describes its objectives as follows: to ensure “judicious use of available water resources”, to provide 24-hour, good-quality water provision to the entire population, and to extend wastewater services to the entire population.²³ In July 2014, it published a National Water Policy, which can be seen as the first step toward a holistic framework for an integrated water legislation (Ministry of Energy and Public Utilities, 2014). This National Water Policy proposes a new approach for water sector governance, identifies areas of future reform and provides an action plan for the government. However, progress was halted by national elections in December 2014, which brought in a new government. Although the new government asserts the need for water sector reform, it is questionable whether it will implement the 2014 National Water Policy.

The MEPU is responsible for proposing legal frameworks for the entire water sector but the legislative power lies with the National Assembly. Annex A contains a list of the water legislation and regulations in Mauritius and their main features. Other governance functions – identified in the matrix of the micro-institutional setting for water sector governance in Mauritius – concern planning, monitoring, and enforcement tasks.

The MEPU also has a number of parastatal organizations and other bodies under its umbrella – namely, the Central Water Authority, the Wastewater Management Authority, the Water Resources Unit and the Water Advisory Council. The latter was created in 1985 but has not been functional until very recently. The MEPU can be described as the line ministry of water. The fact that it has control over the most important micro-institutions related to water shows its dominant role in the sector.

According to our governance survey, the Ministry itself defines its main role in water governance as setting strategies and developing policy outlines for the entire water cycle – in other words, drinking water provision through to wastewater services. As such, it acts as a line ministry for water issues. However, responses to the survey questions indicate that the MEPU does not undertake specific efforts to coordinate issues that fall within the water-food-energy nexus or urban and regional planning activities,²⁴ nor does it provide a coordination platform where various water actors could meet to share information and discuss their respective actions with regard to the water sector.²⁵ In fact, the MEPU identifies the overlapping, unclear and non-existent allocation of responsibilities, and the absence of clearly defined objectives and indicators, as the major impediments to effective coordination between the various water actors. This might be linked to the absence of information for policymakers and a lack of political commitment and leadership, also

²² <http://publicutilities.govmu.org/English/AboutUs/Pages/default.aspx> (01.05.2015).

²³ <http://publicutilities.govmu.org/English/Pages/default.aspx> (01.05.2015).

²⁴ One notable exception are the broad environmental guidelines for Smart Cities underpinning green options for water supply, such as rainwater collection.

²⁵ It is also worth noting that the Ministry does not provide a platform to formally involve water users in governance.

highlighted as important impediments to the coordination of water actors. Findings from the survey also reveal that a further obstacle to effective coordination lies in the fact that reforms initiated by one government are subsequently discontinued by the next. For instance, one idea for reform in the past was to merge several water institutions under a single body – more specifically, to merge the Central Water Authority and the Wastewater Management Authority, both of which are parastatal organizations under the aegis of the MEPU, together with the Irrigation Authority which falls under the Ministry of Agro Industry and Food Security. Although this idea has not completely disappeared and is still mentioned by water actors, according to the survey data, this reform has been discontinued.

Another example is the attempt to introduce a Public-Private Partnership for the provision of drinking water. In 2000, a consortium of French water companies, together with a local partner, were given an 18 month management contract to introduce new technologies for detecting leaky pipelines. The idea was that this management contract would be followed by a 25 year contract, similar to a concession. A public tender was organized and five bidders submitted offers. However, following a change of government later that year, the project was brought to a halt.

Similarly, a Utilities Regulatory Authority Bill that was passed in Parliament in 2004, with the aim of creating a regulatory agency for utilities, has not been subsequently proclaimed. However, according to one interviewee, the idea of an independent utility regulator is still pending and might yet come back on the agenda. Indeed, the Bill was recently amended in June 2016. It remains to be seen whether the Bill will lead to the creation of a utility regulatory authority, and to what extent this will involve the water sector.

On its website, the Ministry states that it is vital to ensure the development of water resources, and the provision of water and wastewater services to guarantee sustainable development. Furthermore, water and wastewater services should be delivered at affordable prices²⁶ – which can be seen as a desire to address social sustainability. However, this assertion does not translate into concrete governance mechanisms other than keeping tariffs so low that they do not cover investment costs. Yet, the National Water Policy, developed by the former MEPU, places a strong emphasis on sustainability concerns in its various aspects: environmental, economic and social (Ministry of Energy and Public Utilities, 2014, pp. 10 ff.). Interestingly, the current MEPU acknowledges in its responses to the survey that the lack of political will constitutes a very important challenge for governance in the water sector and regrets the absence of a valid National Water Policy. To what extent the 2014 National Water Policy, developed by the former government, will be brought into play, remains to be seen. In light of the failure to adopt the policy, it is hardly surprising that the MEPU does not see sustainability as a major cause for concern in water sector governance (as revealed in the responses to the survey). For instance, according to the Ministry, cost recovery – a prerequisite for economic sustainability – has not been perceived as an important governance challenge for a very long time. It is only very recently that the Minister started announcing the need to increase tariffs in order to improve the Central Water Authority's budgetary situation. This could be very cautiously seen as a signal of a

²⁶ <http://publicutilities.govmu.org/English/AboutUs/Pages/Mission-and-Vision.aspx> (01.05.2015).

change in policy. Whether it is followed with concrete measures is yet to be seen.²⁷ The Central Water Authority would welcome an increase in tariffs since it deplors the fact that it cannot recover its costs. The next subsection elaborates on this.

Central Water Authority

The Central Water Authority (CWA) was established in 1971. It is the operative arm of the MEPU,²⁸ and the parastatal body responsible for the provision of drinking water services. Until 1993, it was also responsible for water resources. This function has since been taken over by a newly-created micro-institution, the Water Resources Unit.²⁹ The CWA's Board members are appointed by the Minister, who must approve the budget *ex ante* and who also has the right to give directions.³⁰ Independence from the MEPU is, therefore, very limited.

The CWA is involved in data collection, planning and monitoring activities primarily concerning drinking water services, and to a lesser extent, water resources. For instance, the CWA monitors salinity and the level of heavy metal residues in public boreholes. It also has laboratories that monitor the quality of drinking water before it is injected into the distribution network (National Economic and Social Council, 2014, p. 11). Although the CWA's monitoring activities show that the distributed drinking water is generally safe for human consumption and in accordance to standards set by the World Health Organization, there are concerns about the safety of drinking water when it arrives at the consumer.³¹ The crucial issue is, therefore, whether the water flowing from the tap is safe for human consumption. It is possible for water in leaking pipes to be contaminated with bacteria and parasites. This risk is even higher when the pressure in the pipes is low, a typical problem in Mauritius, where many households rely on private pumps connected to the domestic pipe system to achieve sufficient pressure for tap water. It is also important to note that some users illegally install pumps directly into the CWA water pipeline, further reducing the water pressure for other users. In addition, in Mauritius, 42.7 percent of households do not have a continuous water supply, with 25 percent only receiving water for 10-17 hours a day and 1.4 percent receiving water for less than 10 hours a day (Proag, 2014, p. 4). This means that for long periods, no water is flowing in the distribution system, making it easy for contaminating agents to penetrate through cracks and leaks. Hence, it is possible that water, that was of satisfactory quality at injection, might be contaminated later on in the distribution system.

²⁷ <http://defimedia.info/ivan-collendavelloo-hausser-les-tarifs-pour-assainir-les-finances-de-la-cwa> (20.09.2016).

²⁸ <http://publicutilities.govmu.org/English/AboutUs/Pages/default.aspx> (01.05.2015).

²⁹ The Water Resources Unit is not a parastatal body with a proper legal framework but a department of the Ministry of Energy and Public Utilities.

³⁰ <http://cwa.govmu.org/English/AboutUs/Pages/About-CWA.aspx> (27.04.2015).

³¹ One interviewee raised concerns about the quality of drinking water even at the stage where it is injected into the network. The drinking water is not tested for many pesticides and fertilizers which are commonly used in Mauritius and the respondent claimed that drinking water is in fact contaminated with these substances. This could lead to severe long-term health problems.

In order to address the question of drinking water quality, it is therefore necessary to test the water at the taps. Such monitoring, however, is not routinely carried out in Mauritius, except for tap water in public buildings such as schools and hospitals, which are tested by the CWA and the Ministry of Health. The CWA justifies the absence of monitoring of the water quality after injection into the distribution network by pointing to the consumers' responsibility for their internal distribution network. From the point where the CWA's pipelines end, it is indeed the consumer's responsibility to keep their internal distribution network, as well as their water tank, clean from contaminating agents. Furthermore, according to the CWA, the only time that consumers complain about the quality of drinking water is after heavy rains and cyclones, which may cause turbidity in water, giving it a murky aspect. At such times, the relevant authorities typically advise the population to boil tap water before drinking it. The CWA's argument has some weaknesses though. The fact that tap water appears safe for consumption – based on its appearance, odor and taste – does not guarantee that it has not been contaminated after having been injected into the distribution network. This contamination might be undetectable to the naked eye. Resulting adverse health effects might then not be attributed to the contaminated water but to other causes. Therefore, the argument that consumers do not complain about the quality of the drinking water that flows from their tap does not necessarily imply its quality is fine. Given the leaks in the distribution network, coupled with the problems of discontinuous supply and low pressure, tap water may be contaminated despite the injection of clean water into the distribution system. Because consumers are responsible for the hygiene of their internal water distribution network, the CWA should monitor the water not only at the point of injection into the distribution network, but also at the point where it leaves the CWA's network to enter the household's network. Only if such tests show that the quality of the drinking water is irreproachable, is it safe to conclude that the leaky pipelines of the CWA's distribution system are not a concern for public health. To conclude, the CWA's monitoring of water quality in its current state, because of the lack of routine checks of the quality of water that arrives at the household, can be considered a gap in Mauritian water sector governance.³²

Furthermore, according to the CWA, problems relating to information management create important obstacles to effective coordination between water actors. For instance, a lack of common framework for information means that different water actors work with data that is not defined in the same way, leading to inconsistencies and making comparisons more difficult (although it is noted that these differences are not very important). More critical is a lack of internal communication, which reduces the effectiveness of the flow of information and decisions within the CWA. This issue typically emerges when different officers attend consecutive meetings on the same subject and important decisions are not passed on or followed up. However, the CWA's Board is now committed to address these specific internal management issues and is developing a new management information system.

With regard to sustainability, it seems that the CWA is aware that the very low tariffs and the high rate of Non-Revenue Water (between 50 and 55 percent) make its services

³² At times, the Ministry of Health and Quality of Life will take samples from household taps, but only in specific cases (see subsequent subsection on the Ministry of Health for more on this).

economically unsustainable. As a consequence, special programs for replacement and rehabilitation of ailing infrastructure have been designed. However, the execution of these plans has, to date, been slow and lagging behind set targets (National Economic and Social Council, pp. 14 f.).³³ At the same time, tariff increases, that are needed to cover costs for investments, have been politically undesirable for a long time (ibid., 2014, pp. 21 ff. and 28). In fact, the current government announced in its 2015 budget, that a new policy will be implemented, whereby the first six cubic meters of water would be provided to households free of charge. The CWA is faced with the difficulty of implementing a policy which will further endanger the economic sustainability of its activities and put even more pressure on its already fragile budget. Discussions are ongoing about whether these six cubic meters should be free to all consumers, or only to those consuming not more than six cubic meters, or only to those in low-income brackets. According to our survey, the CWA is aware that its tariffs are among the lowest in Africa. Therefore, issues relating to social sustainability and the users' ability and willingness to pay are of little concern. The typical water bill only amounts to 0.6 percent of the average household income in Mauritius,³⁴ which is much lower than what is usually considered an affordable water bill – somewhere between 2.5 and 5 percent of household income (National Economic and Social Council, 2014, p. 24). It is only very recently, that the Ministry of Energy and Public Utilities has started mentioning tariff increases.³⁵

The financial viability of the CWA is recognized as a very important governance challenge in the water sector. This issue is exacerbated by other very important governance challenges revealed through the questionnaire: the CWA is responsible for drinking water provision, which is why water tariff levels should reflect real costs – in other words, costs for investments as well. In Mauritius, investment in the physical infrastructure is much needed, because a huge portion of the pipe network is non-performing. The CWA, however, is not generating sufficient funds for reinvestment and expansion of the network. Instead, it relies heavily on loan funding, but its debt repayment capacity is very low due to high levels of Non-Revenue Water (exceeding 50 percent). At the same time, the CWA lacks independence from the MEPU and tariffs are set by the government. This leads to what is typically referred to as a 'time inconsistency' problem, whereby rather short-term oriented political considerations – gaining political support – take precedence over necessary long-term considerations; a problem which is particularly acute in the water sector, where pipelines have a life span of up to 100 years.

³³ An interesting point was raised by one respondent: because of Mauritius' small size, no more than 200 km of pipes per year can be replaced without seriously disrupting the country's economy. With 1,600 km of pipes in need of replacement, this would require at least eight years of work.

³⁴ According to the Central Water Authority, the average drinking water bill amounts to MUR 185 (USD 5.28) (CWA, as cited in National Economic and Social Council, 2014, p. 24) and according to Statistics Mauritius, the average disposable household income in 2012, the latest figure, was MUR 29,360 (USD 833) (<http://statsmauritius.govmu.org/English/StatsbySubj/Pages/HBS2012.aspx> (04.08.2016)).

This differs slightly from the figure given in Chapter 3.7 (0.7 percent), which is based on data from the household water survey.

³⁵ <http://defimedia.info/ivan-collendavelloo-hausser-les-tarifs-pour-assainir-les-finances-de-la-cwa> (20.09.2016).

The CWA also sees environmental sustainability as a major governance challenge, particularly in relation to climate change. Rainfall patterns have become more unpredictable, leading at times to water resource deficiency for prolonged periods. This problem is exacerbated by newly emerging forms of pollution endangering water resources, boreholes drying up faster during dry seasons, and by the danger of seawater seeping into underground water reservoirs as a result of overexploitation. Technological innovation might be one way to solve these issues but, as the survey reveals, there seems to be a lack of capacity in the CWA because of unattractive salary packages and the fact that state of the art technology is prohibitively expensive. For these reasons, the CWA is currently considering looking for a private partner in the hope of becoming more efficient and benefiting from its technological expertise.

All in all, our research reveals that the CWA is well aware of the lack of economic sustainability of drinking water services for which it is responsible. This subsection has also shown that environmental sustainability is at stake because of the risk of contamination of drinking water in the distribution network.

The analysis of the CWA's role for water sector governance indicates that the main reason for the lack of sustainability is that, although the CWA is responsible for providing drinking water, it is short of decision-making power and the power to raise funds.

Wastewater Management Authority

The Wastewater Management Authority (WMA) was created in 2001 and is responsible for wastewater services. Like the CWA, it falls under the responsibility of the MEPU,³⁶ its Board is appointed by the Minister (Wastewater Management Authority Act §11(1)), its budget must be approved *ex ante* (Wastewater Management Authority Act §24) and the Minister can give directions (Wastewater Management Authority Act §9). With the exception of strategic planning and stakeholder coordination, this micro-institution is involved in all tasks relating to water sector governance of relevance to wastewater.

The responses to the water governance survey highlight similar issues to those of the MEPU and CWA. There are a number of major obstacles to effective coordination between water actors: a lack of common information, objectives and indicators; a lack of leadership and political commitment; and overlapping and poorly-defined responsibilities.

The survey and the workshop also revealed the WMA's concern for economic sustainability, particularly as the agency's funding has been reduced rather than increased, making it more and more difficult to provide the required investments to replace pipelines where needed and to extend the network.

³⁶ <http://publicutilities.govmu.org/English/AboutUs/Pages/default.aspx> (01.05.2015).

Water Resources Unit

The Water Resources Unit (WRU), established in 1993, is responsible for the assessment, development, management and conservation of water resources.³⁷ It also falls under the responsibility of the MEPU.³⁸ Unlike the CWA and the WMA, however, the WRU is not a parastatal body but rather a department of the Ministry. It is involved in data collection and monitoring,³⁹ and also grants water rights to private users – permits to abstract raw water either from a river or canal flowing through private property or through a private borehole. In addition, it coordinates various stakeholders related to water resources.

In many high-income countries, the governance of water resources is very distinct from the governance of water services (drinking water and wastewater). Each of these sectors has its own specific set of policies and actors with (generally) well-delineated responsibilities. Such is the case in France, for instance, where water resource governance takes place at the river basin level and involves the *Agences de l'Eau* (water agencies); and where the governance of water services takes place at the local level. In many developing countries, however, there is only one overall water sector, as is the case in Mauritius. This means that the policies for water resources are not distinct from the policies of water services, and that the different agencies have little autonomy. This is important since it might explain the supply-side driven approach to Mauritian water policy. Mauritius' response to the perceived water scarcity is to augment the capacity for water storage through the construction of new dams and reservoirs – effectively annexing water resources. It could be argued that this is due to the absence of a distinct approach to water resource governance. Particularly in light of climate change, this could have repercussions for sustainability, both economic and environmental: economic, because funds are directed toward the creation of new dams and reservoirs even though other solutions to address water scarcity might exist; environmental because the alteration of natural water flows has negative environmental impacts. The National Water Policy (Ministry of Energy and Public Utilities, 2014, pp. 20 f.) could be interpreted as a desire to move toward more specific water resource governance with a plan to develop a full-cost approach relating to these resources.

According to the responses to our survey, one issue that hampers the coordination between the CWA and the WRU is the fact that the WRU does not have any specific legal framework. Rather, its role and responsibilities are embedded in the CWA Act. For this reason, respective tasks and functions are not clearly demarcated resulting in overlapping responsibilities.

Another issue hampering governance is the existence of water rights, which allow their holders to control a major part of total water resources in Mauritius. These water rights holders constitute a very powerful lobby and any attempt to revoke these rights over the years, or to reform the water rights system, has been largely unsuccessful.

³⁷ <http://publicutilities.govmu.org/English/WRU/Pages/default.aspx> (27.04.2015).

³⁸ <http://publicutilities.govmu.org/English/AboutUs/Pages/default.aspx> (01.05.2015).

³⁹ <http://publicutilities.govmu.org/English/WRU/Pages/default.aspx> (27.04.2015).

Ministry of Environment, Sustainable Development, Disaster and Beach Management

The Ministry of Environment is involved in water sector governance in so far as environmental considerations of water resources and water services are concerned. More precisely, its tasks include strategic planning, the definition of rules, monitoring (through the Pollution Prevention and Control Division, and the National Environmental Laboratory) and enforcement of decisions (through its Law and Prosecution Division). The latter task is executed with the help of, among others, the Environmental Police which forms part of the Ministry. The Environmental Police has a hotline which citizens can call to make complaints, which are then examined.

The National Environmental Laboratory analyses the quality of surface water. It also assists the enforcing agencies of the MEPU, the CWA and the Ministry of Health in all surface and drinking water quality issues, if there are doubts concerning the accuracy of the agencies' measures.

As the Ministry's name suggests, sustainability considerations form part of its approach toward the environment. However, the implications this has for the water sector, other than environmental legislation, have not been identified.

Ministry of Health and Quality of Life

The Ministry of Health is involved in the monitoring of the quality of drinking water. It is, in fact, the enforcement agency for drinking water quality under the Environment Protection Act. As such, it ensures a regular monitoring of drinking water through daily sampling exercises and analysis of the bacteriological and physio-chemical parameters. On average, 5,000 samples are taken and analyzed yearly. The sampling points are primarily located at outlets of treatment plants and service reservoirs, so as to cover the water being distributed throughout the island. The samples are analyzed in the Ministry's laboratories. In addition, *in-situ* testing of residual chlorine is conducted at the sampling point, so as to prevent microbial contamination within the pipelines during distribution. Samples of drinking water are also taken on a regular basis at sensitive locations such as hospitals, the airport, office buildings and schools. As such, the sampling and analysis conducted by the Ministry, provides a representative coverage of the island, but with an emphasis on treatment plants and sensitive end users.

The Ministry of Health and Quality of Life does not usually take samples from household taps; although it may take random samples if complaints are received or when notable cases of water-related diseases are reported in a specific area.

Ministry of Agro Industry and Food Security / Irrigation Authority

The Ministry of Agro Industry and Food Security houses the Irrigation Authority, which helps the agricultural sector in the planning and execution of irrigation projects. To facilitate coordination between water actors, it had been envisaged in the past to merge the CWA,

the WMA, and the Irrigation Authority into one major water authority. However, according to the respondents, these plans are currently on hold.

4.4 The Micro-institutional Set-up for Mauritian Water Sector Governance

Using the theoretical framework developed in Chapter 4 and the collected data, it is now possible to draw a precise picture of the set-up for water sector governance in Mauritius. Table 35 (below) shows a matrix which depicts which micro-institutions carry out which tasks, for specific dimensions of the governance of water resources, drinking water services and wastewater services.

Several aspects emerging from the governance matrix are worth highlighting. Firstly, there is very little vertical decentralization in the water sector in Mauritius. Whereas, in most other countries water services are organized at the local level, water services in Mauritius are organized at the national level. Similarly, water resource governance is conducted at the national level, not at the river basin level. Nath and Schroeder (2007, p. 123) point out that even compared to other developing countries, there is very little vertical decentralization in Mauritius. Neither local councils (municipal or village) nor regional councils (district), or any of their attached bodies, are involved in the water sector. The size of Mauritius – the country has a surface area of only 1,870 km² – might in itself provide an explanation for the vertical centralization of water sector governance. In fact, its area is roughly equivalent to the average Dutch waterboard or French Water Resource Planning and Management Unit (*Schéma d'Aménagement et de Gestion des Eaux, SAGE*). Given the size of the country, a national level approach to water governance is more appropriate – at least for water resource governance.⁴⁰ According to the fiscal federalism literature, the advantages of centralization at the national level are, among others, the existence of economies of scale and scope realized by national rather than local bureaucracies (Prud'homme, 1995, p. 209) and the prevention of a duplication of bureaucracies and therefore waste (Treisman, 2002, p. 7). In addition, the absence of vertical decentralization in the Mauritian context helps economize on transaction costs: the big reservoirs in Mauritius provide water to several localities in different districts, simultaneously. If water sector governance was vertically decentralized, this could lead to typical issues arising from shared resources, which have attracted a lot of attention in the literature on transboundary water governance.⁴¹

⁴⁰ Our thanks go to Bernard Barraqué, emeritus professor at AgroParisTech, for bringing this to our attention.

⁴¹ We are grateful to Virendra Proag, associate professor of civil engineering at the University of Mauritius, for bringing this point to our attention.

Table 35: Micro-Institutional Setting for Water Sector Governance in Mauritius

			Tasks of water sector governance					
			Collection of information and data	Strategy and planning, i.e. policy outline	Definition of rules	Monitoring of implementation of existing rules	Enforcement of decisions	Coordination of stakeholders, e.g. government bodies, users
Dimension of water sector governance	Water resources	Quality / environment	<ul style="list-style-type: none"> • Water Resources Unit • Central Water Authority 	<ul style="list-style-type: none"> • Ministry of Energy and Public Utilities • Environment Coordination Committee • Water Resources Unit 	<ul style="list-style-type: none"> • National Assembly (CWA Act, Environment Protection Act, Rivers and Canals Act) • Environment Coordination Committee 	<ul style="list-style-type: none"> • Water Resources Unit • Central Water Authority • Ministry of Environment (Pollution Prevention and Control Division, National Environmental Laboratory) 	<ul style="list-style-type: none"> • Ministry of Environment • Environment Coordination Committee • Environmental Police (under ME) • Water Resources Unit • Ministry of Energy and Public Utilities • Ministry of Health and Quality of Life • Central Water Authority 	<ul style="list-style-type: none"> • Water Resources Unit • Environment Coordination Committee
		Allocation / access	<ul style="list-style-type: none"> • Central Water Authority • Water Resources Unit • Irrigation Authority 	<ul style="list-style-type: none"> • Ministry of Environment (Climate Division) • Ministry of Energy and Public Utilities • Water Resources Unit • Irrigation Authority 	<ul style="list-style-type: none"> • Ministry of Energy and Public Utilities • National Assembly (Ground Water Act and Rivers and Canals Act) 	<ul style="list-style-type: none"> • Water Resources Unit 	<ul style="list-style-type: none"> • Water Resources Unit • Central Water Authority • Supreme Court of Mauritius 	<ul style="list-style-type: none"> • Water Resources Unit

		Tasks of water sector governance							
		Collection of information and data	Strategy and planning, i.e. policy outline	Definition of rules	Monitoring of implementation of existing rules	Enforcement of decisions	Coordination of stakeholders, (government bodies, users)		
Dimension of water sector governance	Drinking water	Tariffs	<ul style="list-style-type: none"> Central Water Authority 	<ul style="list-style-type: none"> Central Water Authority 	<ul style="list-style-type: none"> Ministry of Energy and Public Utilities 			<ul style="list-style-type: none"> Water Advisory Council 	
		Service quality		<ul style="list-style-type: none"> Ministry of Energy and Public Utilities 				<ul style="list-style-type: none"> Water Advisory Council 	
		Consumer protection	<ul style="list-style-type: none"> Water Advisory Council 		<ul style="list-style-type: none"> Ministry of Industry, Commerce and Consumer Protection 	<ul style="list-style-type: none"> ACIM (Consumer Association of Mauritius) 			<ul style="list-style-type: none"> Water Advisory Council
		Safety regulation	<ul style="list-style-type: none"> Central Water Authority 	<ul style="list-style-type: none"> Environment Coordination Committee 	<ul style="list-style-type: none"> Ministry of Environment Environment Coordination Committee Ministry of Health 	<ul style="list-style-type: none"> Central Water Authority Ministry of Health and Quality of Life 	<ul style="list-style-type: none"> Ministry of Environment Environment Coordination Committee 		<ul style="list-style-type: none"> Water Advisory Council Environment Coordination Committee
		Technical regulation			<ul style="list-style-type: none"> Ministry of Energy and Public Utilities Ministry of Industry, Commerce and Consumer Protection 	<ul style="list-style-type: none"> Ministry of Energy and Public Utilities 			
		Social regulation	<ul style="list-style-type: none"> Central Water Authority 	<ul style="list-style-type: none"> Ministry of Energy and Public Utilities 	<ul style="list-style-type: none"> Ministry of Energy and Public Utilities 				<ul style="list-style-type: none"> Water Advisory Council

		Tasks of water sector governance						
		Collection of information and data	Strategy and planning, i.e. policy outline	Definition of rules	Monitoring of implementation of existing rules	Enforcement of decisions	Coordination of stakeholders, e.g. government bodies, users	
Dimensions of water sector governance	Wastewater	Environment	<ul style="list-style-type: none"> Wastewater Management Authority 	<ul style="list-style-type: none"> Ministry of Energy and Public Utilities Environment Coordination Committee 	<ul style="list-style-type: none"> National Assembly (CWA Act, Environment Protection Act) Environment Coordination Committee 	<ul style="list-style-type: none"> Wastewater Management Authority 	<ul style="list-style-type: none"> Ministry of Environment Environment Coordination Committee Environmental Police (under ME) 	<ul style="list-style-type: none"> Environment Coordination Committee
		Tariffs	<ul style="list-style-type: none"> Central Water Authority Wastewater Management Authority 	<ul style="list-style-type: none"> Ministry of Energy and Public Utilities 	<ul style="list-style-type: none"> Ministry of Energy and Public Utilities Parliament 		<ul style="list-style-type: none"> Central Water Authority Ministry of Energy and Public Utilities 	
		Technical regulation	<ul style="list-style-type: none"> Wastewater Management Authority 	<ul style="list-style-type: none"> Ministry of Energy and Public Utilities 	<ul style="list-style-type: none"> Ministry of Energy and Public Utilities Wastewater Management Authority Ministry of Industry, Commerce and Consumer Protection 	<ul style="list-style-type: none"> Wastewater Management Authority 	<ul style="list-style-type: none"> Wastewater Management Authority Ministry of Health and Quality of Life 	
		Social regulation	<ul style="list-style-type: none"> Wastewater Management Authority 	<ul style="list-style-type: none"> Ministry of Energy and Public Utilities 	<ul style="list-style-type: none"> Ministry of Energy and Public Utilities 	<ul style="list-style-type: none"> Ministry of Energy and Public Utilities 	<ul style="list-style-type: none"> Ministry of Energy and Public Utilities 	<ul style="list-style-type: none"> Ministry of Energy and Public Utilities

Source: Author's own compilation

Secondly, at the national level, a multitude of actors is involved in Mauritian water sector governance, resulting in a horizontally decentralized setting. The major actors are the MEPU and its subsidiary bodies (the WRU, the CWA and the WMA); the National Assembly; the Ministry of Agro Industry and Food Security and its subsidiary, the Irrigation Authority; the Ministry of Environment, and its National Environmental Laboratory and Law and Prosecution Division; and the Ministry of Health and Quality of Life (in particular, the Environmental Health Unit). There is also a Water Advisory Council, which has been provided for in the Mauritian legislation since 1985, but which has not been functional until very recently. Treisman (2002) points out that an institutional setting involving many different actors might lead to a lack of coordination, resulting in high transaction costs. In light of this, it may be argued that the beneficial effects of possible cost and efficiency savings linked to vertical decision-making centralization might be negated by high transaction costs caused by the horizontal decentralization of Mauritian water actors.

This last point leads us to the third important aspect that emerges from the governance matrix. The multitude of actors involved in the Mauritian water sector is likely to result in a number of governance issues. For one, coordination problems need to be considered. In addition, since a number of different bodies are simultaneously responsible for certain functions – for example, the monitoring of the quality of water resources – there is an inherent risk of duplication if tasks are not clearly allocated across the various actors. This might hamper the efficiency and effectiveness of governance. The data collected through the governance survey, the workshop and the interviews corroborates these views – this will be analyzed in more detail in Chapter 5.

Fourthly, it also appears that water users' associations, although an important stakeholder, are not formally involved in the governance of the Mauritian water sector. They are not part of the Water Advisory Council, nor are they represented in any of the agencies. Although a consumer association defends the interests of water users, it does not have a specific public mandate to do so.

Finally, the matrix clearly shows the prominent role of the MEPU, which is involved in almost every aspect of water sector governance. The MEPU also acts as the line ministry for water since it has under its umbrella, along with the Water Advisory Council, all of the most important micro-institutions: the CWA (responsible for drinking water services), the WMA and the WRU. Provided that the MEPU exerts strong leadership in the water sector, transaction costs can be reduced through the coordination of the various water actors. However, as already mentioned in subsection 4.3, the MEPU does not appear to exert effective leadership. It is therefore not clear whether the role of the MEPU reduces or increases transaction costs.

4.5 Conclusion

This chapter provides an analysis of the institutional setting of water sector governance in Mauritius and the extent to which water actors take sustainability considerations into account.

First, the crucial role of governance for water sector performance was discussed. Dysfunctions in the water sector, such as high rates of Non-Revenue Water or leakage from pipelines, can result from inappropriate mechanisms to oversee, plan, direct, monitor and enforce water transactions. It is also clear that, because water involves many stakeholders, a multitude of actors are involved in water governance.

Then, a framework was developed to depict the micro-institutional setting for water sector governance. An original set of qualitative data was collected in order to understand the respective roles and functions of the various water actors. With the help of this data, a governance matrix was constructed. This matrix identifies which actors are responsible for the different aspects of water sector governance in Mauritius. Specific attention was given to sustainability considerations of the various water actors.

The findings can be summarized as follows. Firstly, unlike most countries, Mauritian water sector governance is not vertically decentralized. The responsibilities for all tasks related to governance lie with actors at the national level. This might not be too surprising given the size of the island and its population of barely 1.3 million. This may have some advantages as vertical decentralization bears the risk of high transaction costs related to coordination in multi-level and multi-actor settings. The MEPU (2014, p. 23) under the previous government envisaged a vertical decentralization of responsibilities, but according to our research, there is a perception among stakeholders that the current government will not go forward with these reforms.

Secondly, as expected, water sector governance in Mauritius involves a multitude of different actors, although all at the national level. Interestingly, none of these actors are independent. Either, they are a division of a Ministry, such as the Pollution Prevention and Control Division of the Ministry of Environment, or they are parastatal bodies, such as the CWA, under the close control of the relevant Ministry, in this case the MEPU. Because coordination in a multi-actor setting generates transaction costs, a line ministry like the MEPU might help to minimize these costs if it takes on an effective leadership role. However, according to the data collected, the perception is that the Ministry does not assume this role. One reason for this lack of leadership could be insufficient personnel.

With regards to sustainability considerations, some of the water actors, such as the CWA, are acutely aware of sustainability issues in the Mauritian water sector. However, our analysis reveals that these actors do not have sufficient decision-making powers to address such concerns. In fact, none of the water actors are autonomous. Many of them depend on the MEPU as their line ministry. Our analysis has, therefore, shown that the sustainability of various aspects of the Mauritian water sector is endangered. In order to better understand why governance in the Mauritian water sector does not sufficiently address sustainability, it is necessary to go beyond an analysis of the institutional setting. Answering this question requires a close study of the problems and issues encountered by the various actors in water sector governance. This is the focus of the following chapter (Chapter 5).

References

- Akerlof, G. A. (1970). The Market for “Lemons”: Quality Uncertainty and the Market Mechanism. *The Quarterly Journal of Economics*, 84(3):488-500.
- Andres, L., Guasch, J. L., and Straub, S. (2007). Do Regulation and Institutional Design Matter for Infrastructure Sector Performance? *World Bank Policy Research Working Paper 4378*.
- Estache, A. and Martimort, D. (1999). Politics, Transaction Costs, and the Design of Regulatory Institutions. *World Bank Policy Research Working Paper 2073*.
- Finger, M., Groenewegen, J., and Künneke, R. (2005). The quest for coherence between institutions and technologies in infrastructures. *Journal of Network Industries*, 6(4):227-260.
- Hooghe, L. and Marks, G. (2003). Unraveling the Central State, but How? Types of Multi-Level Governance. *American Political Science Review*, 97(2):233-243.
- Isnard, L. And Barraqué, B. (2010). *Bibliographie commentée*. Deliverable 1 of the research project Eau&3E – La durabilité des services d’eau dans les grandes villes. Project funded by the French Research Agency (*Agence Nationale de la Recherche*).
- Künneke, R. W. and Finger, M. (2007). Technology Matters: The Cases of the Liberalization of Electricity and Railways. *Competition and Regulation in Network Industries*, 8(3):303-335.
- Künneke, R. W., Groenewegen, J. P. M., and Ménard, C. (2010), Aligning Modes of Organization with Technology: Critical Transactions in the Reform of Infrastructures. *Journal of Economic Behavior & Organization*, 75(3):494-505.
- Marques, R. C. (2010). *Regulation of Water and Wastewater Services: An International Comparison*. London: IWA Publishing.
- Maziotis, A. (2012). Breaking Up Water Monopolies: Costs and Benefits. *Global Water Forum Discussion Paper 1239*.
- Ménard, C. (2009a). From Technical Integrity to Institutional Coherence: Regulatory Challenges in the Water Sector. In: Ménard, C. and Ghertman, M. (eds.), *Regulation, Deregulation and Reregulation: Institutional Perspectives*, pp. 83-110. Cheltenham and others: Edward Elgar Publishing.
- Ménard, C. (2009b). Redesigning Public Utilities: The Key Role of Micro-Institutions. In: Kornai, J., Mátyás, L., and Roland, G. (eds.), *Corruption, Development and Institutional Design*, pp. 189-202. Houndmills and others: Palgrave Macmillan.
- Ménard, C. (2009c). Why to Reform Infrastructures and with what Institutional Arrangements? The Case of Public-Private Partnerships in Water Supply. In: Künneke, R. W., Groenewegen, J. P. M., and Auger, J.-F. (eds.), *The Governance of Network Industries*:

Institutions, Technology and Policy in Reregulated Infrastructures, pp. 25-45. Cheltenham and others: Edward Elgar Publishing.

Ministry of Energy and Public Utilities (2014). *National Water Policy*. Port Louis: Ministry of Energy and Public Utilities.

Musgrave, R. A. (1959). *The Theory of Public Finance*. New York: McGraw-Hill.

Nath, S. and Schroeder, L. (2007). A Counterfactual Analysis of Fiscal Decentralization in Small Countries: The Case of Mauritius. *Public Finance and Management*, 7(2):116-148.

National Economic and Social Council. (2014). Management of Water Resources. NESC Report No. 28.

Oates, W. E. (1972). *Fiscal Federalism*. New York: Harcourt Brace Jovanovich.

Oates, W. E. (1999). An Essay on Fiscal Federalism. *Journal of Economic Literature*, 37(3):1120-1149.

OECD (2009). OECD Survey on Water Governance (2009-2010). Paris: OECD.

Peeroo, A. (2012). *Corruption et services publics: le cas du secteur de l'eau*. Saarbrücken: Editions Universitaires Européennes.

Peeroo, A. (2014). *Decentralization and the Water Sector: Institutional Perspectives*. PhD, University of Paris 1 Panthéon-Sorbonne.

Proag, V. (2014). *La distribution d'eau potable à Maurice et à Rodrigues*. Paper prepared for the DEGEZOI conference, Université de la Réunion, October 2014.

Prud'homme, R. (1995). The Dangers of Decentralization. *The World Bank Research Observer*, 10(2):201-220.

Shirley, M. M. (ed.) (2002). Thirsting for Efficiency: The Economics and Politics of Urban Water System Reform. Amsterdam and others: The World Bank.

Shirley, M. M. and Ménard, C. (2002). Cities Awash: A Synthesis of the Country Cases. In: Shirley, M. M. (ed.) *Thirsting for Efficiency: The Economics and Politics of Urban Water System Reform*, pp. 1-41. Amsterdam and others: The World Bank.

Sobhee, S. K. (2009). On Delegating the Distribution Role of Central Government to State Governments: Some Political Economy Issues. *American Review of Political Economy*, 7(1/2):37-50.

Tiebout, C.M. (1956). A Pure Theory of Local Expenditures. *Journal of Political Economy*, 64(5):416-424.

Treisman, D. (2002). Decentralization and the Quality of Government. *Department of*

Political Science University of California Working Paper.

Trémolet, S. and Binder, D. (2010). La régulation des services d'eau et d'assainissement dans les PED: Revue de littérature, éclairages et pistes de recherche. *Agence Française de Développement A Savoir 01*.

Consulted Websites

<http://cwa.govmu.org/English/AboutUs/Pages/About-CWA.aspx> (27.04.2015).

<http://defimedia.info/ivan-collendavelloo-hausser-les-tarifs-pour-assainir-les-finances-de-la-cwa> (20.09.2016).

http://environment.govmu.org/English/Climate_Change/Pages/Climate-Change.aspx (03.05.2015).

<http://oecd.org/governance/regional-policy/44689618.pdf> (31.08.2015).

<http://publicutilities.govmu.org/English//DOCUMENTS/WATERTANK-SPECS.PDF> (27.04.2015).

<http://publicutilities.govmu.org/English/AboutUs/Pages/default.aspx> (01.05.2015).

<http://publicutilities.govmu.org/English/Pages/default.aspx> (01.05.2015).

<http://publicutilities.govmu.org/English/WRU/Pages/default.aspx> (27.04.2015).

<http://statsmauritus.govmu.org/English/StatsbySubj/Pages/HBS2012.aspx> (04.08.2016).

[http://www.dvgw.de/no_cache/angebote-leistungen/regelwerk/regelwerkverzeichnis/?id=28281&tx_dvgwregelwerkverzeichnis\[q\]=w+307](http://www.dvgw.de/no_cache/angebote-leistungen/regelwerk/regelwerkverzeichnis/?id=28281&tx_dvgwregelwerkverzeichnis[q]=w+307) (17.12.2013).

<http://www.dvgw.de/regelwerknews-de/archiv-rw-news/dvgw-regelwerk-newsletter-nr-132007/> (17.12.2013).

<http://www.dvgw.de/regelwerknews-de/archiv-rw-news/dvgw-regelwerknews-nr-608/> (17.01.2013).

Chapter 5: Governance Issues in the Mauritian Water Sector Impeding Sustainability

Aleksandra Peeroo

Introduction

Tortajada's (2010, p. 303) description of low performance services in developing countries with water scarcity aptly describes the water sector in Mauritius: "[...] non-revenue water, often up to 40-60 percent, infrastructure either scarce or becoming complex and deteriorating, water supplies largely underpriced, and investment needs, possibly reaching billions [...]"

When the need for reform is acknowledged by decision-makers, it is often driven by a supply-side approach (World Bank, 2000, p. 9), meaning that water scarcity leads to the development of large-scale infrastructure such as new dams and reservoirs. This is contrary to the more prevalent view that "a 'water crisis' is largely a governance crisis" (OECD, 2011, p. 17). For this reason, there has been a paradigm shift toward demand-based solutions, where the role of institutions is specifically taken into account in order to build sustainable water services (Ferdous Hoque and Gunawansa, 2013, p. 412). Many countries, however, continue to focus on the supply side of the water sector and concentrate on large infrastructure projects rather than looking at the problems from a governance perspective (Falkenmark and Xia, 2013, p. 62).

Mauritius is no exception. Dysfunctions in the Mauritian water sector are usually considered the result of insufficient storage capacity or a desolate distribution network. It is, therefore, not surprising that the 'big reform' and 'restructuring' of the water sector announced by the MEPU at the beginning of 2015, focuses primarily on the construction of new reservoirs and the replacement of leaky pipelines.⁴² Until now, inappropriate governance has not been considered the reason for poor sector performance.

Governance concerns binding decision-making in the public sphere (Hooghe and Marks, 2003, p. 233). In the water sector, it refers to the system in place to oversee, plan, direct, monitor and enforce transactions between the various water uses. Flawed rules and practices for decision-making on water policy and implementation will inevitably lead to poor water sector performance. Even if storage capacity is increased, problems of water scarcity will not be solved as long as unsuitable governance hinders an efficient coordination between the multitude of water actors, thereby preventing effective decision-making and the implementation of decisions. The Mauritian water sector will continue to suffer from issues such as a very high level of Non-Revenue Water (50-55 percent) and remain

⁴² <http://www.lexpress.mu/article/260089/pailles-virulente-sortie-divan-collendavelloo-contre-cwa> (28.06.2016).

unsustainable, if poor governance is not addressed. It is therefore necessary to redirect the public debate toward a greater focus on governance issues.

The literature highlights a number of governance problems. These are not specific to developing countries, yet tend to be more acute in these contexts. One of the most common problems is that of a fragmented institutional setting characterized by an overlapping and unclear distribution of decision-making power (Tortajada, 2010, p. 300).

This chapter is, therefore, dedicated to: (i) analyzing specific issues hindering effective water sector governance in Mauritius and (ii) highlighting the reasons for the failure of governance to sufficiently address sustainability. The remainder of this chapter is organized as follows: Section 5.1 briefly describes how the original data was collected; Section 5.2 presents a number of specific governance issues based on the analysis of the data; Section 5.3 presents the main findings; and Section 5.4 concludes.

5.1 Data

In order to understand the issues that water sector governance faces in Mauritius, a survey has been designed for the purpose of this research. It draws extensively on the OECD Survey on Water Governance (OECD, 2009) and has been adapted to reflect the situation in Mauritius and address sustainability issues.⁴³ The survey can be found in Annex B. The survey was then sent to the main Mauritian water actors. The respondents to this survey were from eight main institutions: the Ministry of Energy and Public Utilities (MEPU), the Water Resources Unit (WRU), the Central Water Authority (CWA), the Wastewater Management Authority (WMA), the Ministry of Health, the Ministry of Agroindustry, the Irrigation Authority and the Ministry of Environment.

The survey was not submitted to the private sector nor to domestic users because, although consumers of water, they are not involved in water sector governance in Mauritius. In fact, these parties have no voice when it comes to decision-making on water issues. The submission of the survey to public decision-makers, therefore reflects the reality of Mauritian water sector governance. In addition, as well as providing an institutional mapping of the allocation of governance responsibilities across the various decision-makers in the water sector, the aim was to highlight the concrete governance challenges these public decision-makers face, given the variety of water actors and stakeholders involved. Furthermore, we endeavored to understand the mechanisms in place to facilitate the coordination of these various actors and stakeholders and to discern the role that sustainability considerations play in Mauritian water sector governance.

The responses to the survey were then used as an indication of the most urgent problems in water sector governance, which were subsequently discussed in a workshop on sustainable water sector governance in Mauritius, involving the eight main Mauritian actors. Because

⁴³ The original OECD survey is available at <http://oecd.org/governance/regional-policy/44689618.pdf> (31.08.2015).

much of this data is sensitive and critical of the *status quo*, the respondents have been guaranteed anonymity.

The collected data highlights a number of governance issues which will be presented in the following section. The main difficulties obstructing efficient governance in Mauritius seem to fall within the categories identified by the literature. Tortajada (2010, p. 303), for one, stresses the problem of the lack of long-term vision for the water sector. Decisions are often made to address more immediate concerns. This is closely linked to the idea advocated by Tortajada that “system-thinking” is needed in the water sector (ibid, p. 304); in other words, strategic planning and a global vision, rather than merely patching up specific ‘hot spots’. The author acknowledges at the same time that this is difficult given the fragmentation of institutions for water governance and the associated lack of clarity in the allocation of, often overlapping, responsibilities (ibid.). This fragmentation also complicates the required coordination of the various water actors, which consequently hampers the implementation of policies (Bied-Charreton et al., 2006, p. 47). An additional prominent governance issue is a lack of transparency (Tortajada, 2010, p. 305). The following section elaborates on these issues, and others, from a Mauritian perspective.⁴⁴

5.2 Governance Issues in the Mauritian Water Sector

Discontinued Water Sector Reforms

The survey revealed that water sector reforms are not followed through and are often discontinued. An illustration of this has already been provided in Chapter 4 – a Public-Private Partnership involving the CWA, a local partner and a consortium of French companies was cancelled by the MEPU following the election of a new government.

The workshop on governance has revealed that although a real paradigm shift in the approach towards reform of the water sector would be needed – in other words, moving away from supply-side driven solutions to the problems encountered – the changes that actually are being made are too small and insignificant to constitute a reform. Nine water reform papers have already been produced by local and external consultants but none of them have been implemented. These reports have become increasingly similar in recent years – an indication that the most important issues in the Mauritian water sector had already been identified in previous reports. The fact remains, however, that these reports, many of which have been described as being of excellent quality, have not been implemented. A common complaint during the workshop was that “they just end up in a drawer”.

This issue of discontinued water reforms is a typical governance problem which results from the so-called ‘time inconsistency’ problem, where short-term political considerations such as gaining political support are more important to decision-makers than long-term

⁴⁴ The analysis of these issues also points to a number of possible solutions and policy recommendations. These are presented in Chapter 6.

sustainability considerations. As previously mentioned, this problem is particularly acute for water utilities because pipelines might have a life span of up to 100 years.

Lack of High-level Political Commitment and Leadership in Water Policy

The time inconsistency issue also explains another common governance problem in public utility sectors – namely, the lack of high-level political commitment. The underlying difficulty is that politicians may be reluctant to push for painful but necessary reforms, such as an increase in tariffs, out of fear of losing the support of citizens, who are not only public utility users, but also voters.⁴⁵ This might explain why a National Water Policy exists in Mauritius but has not been implemented; nor is it clear whether this is likely to happen in the future.⁴⁶ On a smaller scale, it might also explain why the replacement of distribution pipes is more advanced in certain electoral constituencies but not in others. The CWA has a masterplan for renewing the distribution network but in order to implement it, ministerial approval is needed to release the funding; this might not happen unless the works are in the “right electoral constituency”, as one respondent put it.

In addition, even if the MEPU showed greater willingness to take over the leadership of water sector issues, effective leadership might be hindered by the formal set-up of the numerous water actors, as was pointed out by discussions with participants of the workshop on water sector governance. There are, in fact, so many different committees and boards intervening in the decision-making process that the Ministry’s leadership role might effectively be diluted. The matrix depicting the micro-institutional setting of the Mauritian water sector presented in Chapter 4 shows the large number of water actors connected to the Ministry. This dilution of leadership is particularly an issue because responsibilities are not clearly defined across the various water actors.

Moreover, a lack of leadership makes it difficult to manage and sustain projects through from their inception to their end. A particular problem relates to the fact that no government body seems to be accountable for specific projects and, therefore, no agency is willing to take the responsibility for dysfunctions. As a consequence, infrastructure performance is reduced. This is illustrated by disruptions to traffic and economic activity when heavy rainfall causes flooding of a major bridge on the Grand River South-East or similar problems in Rivière du Poste in the south of the island.

⁴⁵ In this respect, it may be welcomed that very recently, the Minister of Energy and Public Utilities announced plans to increase the tariffs for drinking water services. (<http://defimedia.info/ivan-collendavelloo-hausser-les-tarifs-pour-assainir-les-finances-de-la-cwa> (20.09.2016)).

⁴⁶ It should be noted that the underlying concept of the Water Policy – integrated water management – might be effective only in theory. Although it has been extensively promoted in recent decades, Biswas (2008) shows that the results of integrated water management from different parts of the world are disappointing and that it is unlikely to work in the future.

Overlapping, Unclear, non-Existing Allocation of Responsibilities

A number of examples illustrate the problems caused by a lack of a clear demarcation of responsibilities across the actors involved in water sector governance. The WRU, which is responsible for assessment, development, management and conservation of water resources, does not have a legal framework of its own. Rather, its legal framework is embedded in the Central Water Authority Act. As a result, the responsibilities of the CWA and the WRU partly overlap. The implications of this problem are well-known to decision-makers as an unpublished report on this issue already exists.

The absence of a proper legal framework for the WRU also leads to dysfunctions in the enforcement of regulations. For instance, the WRU does not have the tools to prevent the discharge of effluents into water resources despite the fact that it is responsible for water resource conservation.

The discussions with decision-makers also illustrate clearly how this lack of clarity in the allocation of responsibilities hampers the decision-making process in the Mauritian water sector, as well as the enforcement of regulations. It seems that a common issue in meetings involving water decision-makers is which water actor should handle which specific problem. Ministries and parastatal bodies will often argue that the responsibility for a specific issue is not theirs. On one occasion, for example, both the WRU and the WMA argued that the discharge of effluents into sea water was not their responsibility; instead, the issue had to be handled by the Ministry of Fisheries.⁴⁷

Lack of Transparency

Transparency is often seen as key to effective governance and regulation (Tortajada, 2010, p. 305). The perception of water actors, though, seems to be that transparency is lacking in Mauritian water sector governance. It is often unclear how decisions are reached. Furthermore, stakeholders are informed of final decisions without having been properly involved in the decision-making process. This is also true for user participation. Consumers and water users lack a voice in water sector governance and are not formally involved in the decision-making processes. However, it must also be noted that users do not always show enough concern for water policies, as the next point illustrates.

Lack of Citizens' Concern for Water Policy

In recent times, user participation has become a more integral part of water sector governance (Kodjovi, 2011). Users' concerns should be taken into account when water policies are made. At the same time, it is important to educate users. In discussions with the

⁴⁷ An interesting point was raised by a water sector expert who provided an explanation for the overlapping responsibilities of water governance actors. The argument is closely related to Niskanen's model of bureaucratic behavior and empire-building: a new Minister entering office is interested in enlarging his power by increasing the amount of departments he controls. In the process of this empire-building, responsibilities are not clearly demarcated, and often duplicated.

various stakeholders, it appears that users' behavior sometimes goes against the interests of sustainable water utilities. For instance, users' expectations of the CWA may be too high. For example, in one case, inhabitants of Tamarin, who live quite high up a mountain on the west coast of Mauritius, expected to have a large quantity of water with adequate pressure to fill their swimming pool. This is technically very difficult to achieve and also very expensive. Another example is that of a manufacturing company in La Tour Koenig, a dry region suffering from water stress in the northwest of the island, which expanded its operations without taking into consideration the water scarcity. The CWA is unable to provide more water to the company. It appears, therefore, that there is a real need to inform people about water issues, but this is not done. As was remarked during the governance workshop, when people lack information, they might not understand the decisions and therefore become frustrated and revolt.

This also means that users need to be educated to understand that water and wastewater services must be paid for. There is a perception that users are typically more willing to pay for electricity and telecommunications but that they feel that water tariffs should remain very low. Even worse, illegal connections are a real problem in the Mauritian water sector – for example, in Bonne Terre and Carreau Laliane in Vacoas, a municipality in the central region of the island. As well as siphoning of water, illegal connections and pumps reduce the water pressure in the CWA's pipelines, thereby reducing the pressure for other users.

It is therefore important to educate users, to help them understand the sustainability problems that the water sector faces. Users should be aware of the real cost of water in order to prevent the water sector from becoming even more unsustainable through illegal practices or unreasonable expectations. At the same time, it is important to note that, according to the experts that were interviewed, users are willing to pay higher tariffs if the service quality improves.

Interference of Lobbies

Strong political leadership might also be hindered by the interference of lobbies. Our research has shown that this is perceived to be one of the main governance issues in the Mauritian water sector. For instance, government and consumer lobbies try to prevent tariffs from increasing. It is assumed that these lobbies are successful as there were no increases in tariffs between 2002 and 2012, not even to adjust for inflation.⁴⁸ Socio-cultural lobbies demand free water or water at very low tariffs. A question raised by one respondent was why water should be provided for free to these organizations, particularly given the fact that they do not seem to make an effort to save water.

As well as lobbying for low tariffs, our research reveals that that lobbying from water rights holders is very intense. Water rights provide access to water resources, for instance, for industrial or agricultural purposes, at very advantageous conditions. For decades, isolated voices have called for a reform to the water rights system which goes back to 1863, but

⁴⁸ According to one respondent, water tariffs would be around 40 percent higher today if they had been indexed to inflation.

without much success.⁴⁹ Furthermore, there have been indications that even individual users 'lobby' for lower bills and in some cases do not hesitate to resort to bribery.⁵⁰

Lack of Independence of Water Agencies

The lack of political commitment might not be such a big problem if the various water agencies were more independent. Because they lack autonomy, water agencies are highly dependent on the approval of their line ministry to implement their projects and plans. In part, these agencies also depend on each other. Wastewater issues, for instance, should be independent of the CWA, according to the Central Water Authority Act. However, in reality they are not. Wastewater fees are collected by the CWA.

In addition, under the Central Water Authority Act, the CWA should be able to take decisions on its own but in reality it requires the approval of the MEPU, its line Ministry. According to procedure, the CWA needs to approach representatives of the Ministry before an issue is presented to the Minister. However, the Ministry is not involved in the CWA's daily operations and, therefore, does not know the details of the dossier. The Ministry's officers then present the issue to the Minister who will then decide whether to give his approval. During the workshop, it was suggested that one reason why the Minister may refuse a proposal, is that important information may have been misunderstood by Ministry officials so the Minister does not have the correct information on which to base a decision.

It was also noted that a number of water agencies are highly political and that there is an urgent need to de-politicize these institutions. Ministerial approval is often needed to promote officers working at some of the water agencies. Our research has also found that there is a perception that officers are appointed on the basis of their ethnicity, cast⁵¹ or family background.

Absence of Strategic Planning, Global Vision, and Sequencing of Decisions

Another typical governance problem, especially when strong leadership is missing, is the absence of strategic planning and a global vision for the water sector, as well as the sequencing of decisions. Land drainage and works by the CWA and the WMA should be carried out at the same time to guarantee as little disturbance to traffic as possible, particularly in Port Louis, Mauritius' capital, where the streets are very narrow and there is a lot of traffic. This is, however, not the case. In addition, because Mauritius is such a small island, it is not possible to replace more than 200 km of pipes a year because of the disruption it would cause to traffic and economic activity. There is also a lack of

⁴⁹ The water rights issue is quite complex. There is a need to ensure that lobbies are not successful in preventing necessary reform. However, the allocation of water would also require a harmonized Water Act. Water legislation in Mauritius is very scattered and consists of many different legislative texts.

⁵⁰ Commercial losses in the Mauritian drinking water sector, which amount to 10-15 percent (National Economic and Social Council, 2014, p. 15), are not only due to defective meters; corruption provides an additional explanation for Mauritius' high levels of non-revenue water (50-55 percent).

⁵¹ The majority of Mauritius' population is Hindu.

coordination between urban planning, and the water and electricity sectors when it comes to new development projects.

More generally, the water sector and the various water agencies lack a strategic vision. The CWA, for instance, has more of a focus on its operational objectives, rather than any strategic outlook. Therefore, there is a need for global planning for projects, rather than the current haphazard case-by-case planning. The WMA has, in fact, developed a masterplan, but it is not being properly adhered to. The lack of global vision is illustrated by the fact that there seems to be more treatment plants for wastewater in Mauritius than needed. As well as putting a greater strain on the public budget, it also has an impact on environmental sustainability.

Problems in Coordinating the Multitude of Water Actors

Because of the multi-actor nature of the water sector, it is necessary to coordinate their actions. Ineffective coordination will gravely hinder water sector governance since it will lead to information asymmetries, a lack of leadership and difficulties in the implementation of decisions, among others.

A particular issue that can be observed in the Mauritian context is that, sometimes, coordinating bodies exist *de jure*, but not *de facto*. The Water Advisory Council, for example, has been in existence since 1985, but has only very recently been operationalized. Similarly, the National Environment Commission – which is under the chair of the Prime Minister and was set up under the Environment Protection Act 2002, with the aim of developing environmental policies and coordinating stakeholders – held its last meeting in 2003.

It is important to note that even where coordination bodies exist *de facto*, they might not enhance effective governance and, in fact, often dilute decision-making processes (as previously mentioned). Our research has revealed that some of the committees in the Mauritian water sector may add to the administrative burden, resulting in long delays to the implementation of projects as dossiers go back and forth between a multitude of water actors.

Difficulties in Implementing Central Government Decisions at the Local Level

It was also noted that the implementation of central government decisions is sometimes difficult at the local level. For instance, by law, the calibration of bulk water meters has to be done by the metrological department. However, this department lacks the necessary equipment and the bulk meters need to be sent to South Africa for calibration.

More generally, there seems to be a perception that the process of developing and passing new laws is relatively smooth but that implementation is often problematic.

5.3 Findings from the Analysis of Water Governance in Mauritius

The governance challenges faced by the Mauritian water sector corroborate much of the literature on this topic. These challenges are linked to institutional weaknesses pertaining to

issues of transparency, overlapping responsibilities and a lack of a long-term vision. The latter is particularly crucial for the sustainability of the water sector since sustainability explicitly entails catering for the needs of future generations.

The following points seem of particular importance: Firstly, transparency in the governance of the Mauritian water sector is very low – a particularly contentious issue for the National Economic and Social Council (2014, pp. 23 and 28), especially with regards to tariff setting and the costs of the CWA. Water actors also criticize the lack of transparency in decision-making. Related to this is the lack of voice for water users. In an attempt to address these issues, the MEPU (2014, p. 18) proposed, in their National Water Policy, the creation of a Water Observatory and other institutional mechanisms that would be responsible for the collection of coherent and uniform data, and its dissemination.

Secondly, there is a lack of coordination between the various actors. Again, this missing, crucial element is highlighted in the National Water Policy (Ministry of Energy and Public Utilities, 2014, p. 14) which asserts the need for an Inter-Ministerial Committee to ensure a coherent and coordinated approach for the different tasks related to water sector governance. Our water governance survey has revealed these coordination issues. Water actors note the lack of clearly demarcated responsibilities, the absence of commonly-shared data and information, as well as a lack of clear political leadership and will, as being among the main impediments to effective coordination of actors related to water governance. However, to what extent will the creation of yet another micro-institution responsible for water – without first addressing the issue of overlapping responsibilities – improve water sector governance?

Thirdly, sustainability issues are largely ignored. With regard to environmental sustainability, a coherent approach is lacking. Different micro-institutions such as the CWA, the WRU and the WMA, are responsible for tasks related to environmental considerations. Yet, there is no coordination of their efforts. More importantly, the absence of clear data on the water situation in Mauritius prevents effective measures that might foster a sustainable environment. We cautiously express the hope that water accounting will help to better understand environmental issues in the Mauritian water sector.

In terms of economic sustainability, water charges and tariffs in the Mauritian water sector are so low, that they barely, if ever, cover operating costs (National Economic and Social Council, 2014, pp. 23 ff.). They are not sufficient to pay for the investments required to change the roughly 1,600 km of pipes in need of replacement. The recent National Water Policy might provide some hope (Ministry of Energy and Public Utilities 2014, pp. 10, 21). It advocates a full-cost approach, which considers not only operating, maintenance and capital costs, but also the social costs of any negative externalities – in accordance with the ‘polluter pays principle’ and real costs of water resources. However, our respondents advised caution, questioning whether this water policy will ever be implemented. The CWA is well aware of its economic unsustainability and notes that it is difficult even to cover operating costs. The much needed investments to replace ailing pipes are not covered by the tariffs. However, tariffs are set at the Ministry level and the government has always been very reluctant to increase them, at least until now. The CWA lacks the decision-making

power to improve its financial situation and find a solution to the very high levels of Non-Revenue Water (50-55 percent).

With regards to the social aspects of sustainability, the Mauritian situation is such that about one-third of households supplied by the CWA benefit from highly subsidized social tariffs, even though they do not fall into the group of economically vulnerable households (National Economic and Social Council, 2014, p. 27). This does not correspond to the idea of social tariff setting and constitutes a form of public waste that should be quickly addressed by the relevant authorities, if their aim is to increase the efficiency of the water sector. However, the highly politicized nature of the Mauritian water sector means that tariffs are only sporadically and very rarely reviewed. The last tariff increase was in 2012, after ten years of no change. Moreover, the 30 percent increase in 2012 did not cover the cumulative increase in costs since the last tariff revision in 2002 (*ibid*, pp. 22, 28). To what extent tariffs will increase in the future, is yet to be seen.

So why is Mauritian water sector governance not better geared toward sustainability considerations? One explanation might be the problems of time inconsistency and government opportunism, which typically occur in infrastructure with a long lifespan (Savedoff and Spiller, 1999; Ménard and Peeroo, 2011, p. 316). Consider, for instance, the life cycle of water pipes. If properly maintained, these pipes can last roughly 80 years, even longer in some cases. For this reason, elected officials, who usually only remain in power for a couple of terms, are not committed to the long-term sustainability of the infrastructure or concerned about the impacts of the solutions they adopt. In the long run, providers of water services need to recover the high costs of their fixed assets, but in the short-run, they can survive by covering only operating costs, which are well under average costs.⁵² This provides a strong incentive for government opportunism – keeping prices low for electoral gains.⁵³ This also implies that, because decision-making power in the water sector essentially lies with politicians, painful but long-term, beneficial measures and reforms are evaded in order to gain short-term political support. As a result, tariffs may continue to remain artificially low.

5.4 Quo Vadis?

In order to prepare for the potential negative effects of climate change on the water sector, water sector governance in Mauritius needs to address these different issues. Mauritius is already at risk of water scarcity by 2020 (National Economic and Social Council, 2014, p. 20). Therefore, it appears to us that it is of utmost importance that the government and the relevant authorities react immediately to push forward the much needed reforms in the water sector. We share the view in the literature that the focus of reform should be directed toward issues of water sector governance rather than exclusively replacing or constructing new infrastructure.

⁵² This results from the fact that water utilities have the characteristics of a natural monopoly (Noll, 2002).

⁵³ Mauritian water tariffs are among the lowest in Africa and the typical household bill amounts to only 0.6 percent of the average household income (see Chapter 4).

Chapter 6 will elaborate on some policy recommendations for improving water sector governance: to prepare a harmonized Water Act, to give more independence to the main water agencies, to develop performance indicators and make them publicly available, and to introduce benchmark competition.

References

- Bied-Charreton, M., Makkaoui, R., Petit, O., and Requier-Desjardins, M. (2006). La gouvernance des ressources en eau dans les pays en développement: enjeux nationaux et globaux. *Mondes en développement*, 3(135):39-62.
- Biswas, A. K. (2008). Integrated Water Resources Management: Is It Working?. *International Journal of Water Resources Development*, 24(1):5-22.
- Falkenmark, M. and Xia, J. (2013). Urban Water Supply under Expanding Water Scarcity. In: Larsen, T. A., Udert, K. M., and Lienert, J. (eds.), *Source Separation and Decentralization for Wastewater Management*, pp. 59-70. London and New York: IWA Publishing.
- Ferdous Hoque, S. and Gunawansa, A. (2013). Good Governance of Water: The Final Analysis. In: Gunawansa, A. and Bhullar, L. (eds.), *Water Governance: An Evaluation of Alternative Architectures*, pp. 390-418. Cheltenham and others: Edward Elgar.
- Hooghe, L. and Marks, G. (2003). Unraveling the Central State, but How? Types of Multi-Level Governance. *American Political Science Review*, 97(2):233-243.
- Kodjovi, M.-J. (2011). *Les usagers dans la régulation des services d'eau en France*. Saarbrücken: Editions Universitaires Européennes.
- Ménard, C. and Peeroo, A. (2011). Liberalization in the Water Sector: Three Leading Models. In: Finger, M. and Künneke, R. W. (eds.), *International Handbook of Network Industries: The Liberalization of Infrastructure*, pp. 310-327. Cheltenham and others: Edward Elgar Publishing.
- Ministry of Energy and Public Utilities (2014). *National Water Policy*. Port Louis: Ministry of Energy and Public Utilities.
- National Economic and Social Council. (2014). Management of Water Resources. NESC Report No. 28.
- Noll, R. G. (2002). The Economics of Urban Water Systems. In: Shirley, M. M. (ed.), *Thirsting for Efficiency: The Economics and Politics of Urban Water System Reform*, pp. 43-63. Amsterdam and others: The World Bank.
- OECD (2009). OECD Survey on Water Governance (2009-2010). Paris: OECD.
- OECD (2011). Water Governance in OECD Countries: A Multi-Level Approach. Paris: OECD.
- Savedoff, W. and Spiller, P. (1999). *Spilled Water: Institutional Commitment in the Provision of Water Services*. Washington DC: Inter-American Development Bank.
- Tiebout, C.M. (1956). A Pure Theory of Local Expenditures. *Journal of Political Economy*, 64(5):416-424.
- Tortajada, C. (2010). Water Governance: Some Critical Issues. *International Journal of*

Water Resources Development, 26(2):297-307.

World Bank (2000). *Initiating and Sustaining Water Sector Reforms: A Synthesis*. Washington DC: The World Bank.

Consulted Websites

<http://defimedia.info/ivan-collendavello-hausser-les-tarifs-pour-assainir-les-finances-de-la-cwa> (20.09.2016).

<http://oecd.org/governance/regional-policy/44689618.pdf> (31.08.2015).

<http://www.lexpress.mu/article/260089/pailles-virulente-sortie-divan-collendavello-contre-cwa> (28.06.2016).

SECTION THREE: POLICY IMPLICATIONS

Chapter 6: Summary of Key Findings and Policy Recommendations

Aleksandra Peeroo and Riad Sultan

Introduction

This chapter provides a short synthesis of the major findings of our study and presents some policy recommendations. It includes a summary of the water accounts for Mauritius, the estimation of the demand function for water, the analysis of the economic contribution of water, and the forecast of water supply and demand up to 2030. This forecast is based on a scenario-based analysis, taking the likely effects of climate change into account.

The conclusion is that certain issues in the water sector might be related to inadequate governance. Some of the main findings from the governance part of this study are then drawn on in order to propose a number of policy recommendations for a more sustainable water sector.

6.1 Water Accounts

The study compiles four sets of water accounts for the purpose of providing a systematic record on water in Mauritius – namely, water balance, total water abstraction, water abstraction by water supply industry, and supply and use tables. The major findings are as follows:

- There have been large fluctuations in precipitation in recent years. For example, in 2008, precipitation was estimated at 4,440 million m³, while in 2012, it fell drastically to 3,001 million m³. Furthermore, 77.7 percent of rain in 2013 fell during the summer and only 22.3 percent during the winter.
- Of the total available water – in other words, precipitation less evapotranspiration – 8 percent is abstracted through the storage system and 4 percent is utilized by the residential and non-residential sectors (including government sectors).
- Non-Revenue Water (a result of a leaking distribution network, faulty meters and theft) amounts to approximately 50 percent of total available water.
- The agricultural sector, the largest user of water in Mauritius, uses 14.1 percent of total water available. Of the 375 million m³ abstracted by the sector, 98 percent stems from surface runoff. This sector uses only 1.4 percent of the treated water provided by the water supply industry; the remaining is abstracted directly from surface and ground water.

For a proper understanding of the water situation in Mauritius, it was important to prepare water accounts on a seasonal basis – in other words, separate accounts for the winter and the summer seasons. The main findings are as follows:

- The agricultural sector uses much more water in summer but faces a scarcity of water in winter.
- Water demand is more or less constant throughout the year. This implies that in winter, and at the beginning of the summer season (December and January), water supply can scarcely meet demand – largely because of the amount of Non-Revenue Water (50 percent).
- There is a strong correlation between precipitation and water abstracted by the water supply industry, implying that a reduction in precipitation leads to a fall in water stored in the storage system. Studies on climate change impacts on precipitation in Mauritius conclude that under the worst scenarios (A2, A1B and B1 storylines), the fall in precipitation is estimated at between 3 and 9 percent annually in the 2030s. In summer, the worst scenarios conclude that rainfall might decrease by between 10.8 percent and 17.3 percent, while for the winter months, the decrease is estimated at between 18.2 percent and 1.2 percent. This means that there is a high probability that in some years, levels of water abstraction by the water supply industry will be low and, therefore, a water crisis may seriously jeopardize the island.

6.2 Price, Income and Output Elasticity of Water

On the demand side, the study attempts to analyse the current trends as well as future trends in the consumption of water. As an aid to policymaking, the price and income elasticity of water has been calculated for the residential sector as well as the non-residential sector. In the economic sectors, the output elasticity, marginal productivity of water and price elasticity are estimated using a trans-log production function.

- We calculated the price and income elasticities for both the residential and non-residential sectors using an Autoregressive Distributed Lag model. The long-run price elasticity for water is -0.16 for the residential sector and -0.72 for the non-residential sector, respectively. Income elasticity in the long run is estimated at 0.23 for the residential sector and 0.49 for the non-residential sector.
- The study uses a trans-log production function to estimate the output elasticity. Output elasticity for water ranges from 0.02 to 0.47 for the different sectors of the economy. The paper, chemical, rubber, metal, construction and wholesale trade sectors have an average output elasticity of 0.41. The food and textile sectors have a lower output elasticity.

6.3 Household Survey on Water Use

To have a better picture of water use and the impact of water scarcity on households, a survey was undertaken with a sample of respondents across Mauritius. The survey collected information on water use, water bills and socioeconomic characteristics, including income. The survey results show that the ratio of water bills to household income declines as household income rises. This means that the water tariff structure is highly regressive. Moreover, around 43.5 percent of respondents reported owning a water tank. This behavior can be seen as an adaptation strategy to the absence of a continuous water supply in Mauritius.

6.4 Economic Value of Water

The marginal benefit of water used by the residential sector stands at MUR 9.91 per m³ (USD 0.28), while the marginal productivity of water in the manufacturing sector is estimated at MUR 1,413 per m³ (USD 39.8). These values can be used to estimate the economic benefits of investment in reservoirs such as the Bagatelle Treatment Plant, which aims at ensuring a more regular water supply to residents in the district of Port Louis, Lower Plains Wilhems and the northern part of the Black River district. The project costs MUR 1.7 billion (USD 47.9 million) and is expected to mobilize around 25 million m³. This implies that the economic benefits – calculated at MUR 250 million (USD 7 million) a year, using the marginal benefit of water for the residential sector – will outweigh the cost of construction after nearly seven years.

6.5 Forecast of Demand for Water and Climate Change Scenarios

The forecasting exercise estimates the residential and non-residential demand for water in 2030 under three economic growth scenarios – namely, a GDP growth of 2, 5.5 and 7 percent, respectively. Household consumption is estimated at 85 million m³, 99.7 million m³ and 108 million m³, respectively. The total demand for drinking water is projected to be 112.7 million m³, 133.7 million m³ and 146 million m³, respectively. Basing our calculations on the actual water storage system, water abstracted is expected to amount to 220 million m³. Using the actual figures and the rate of distribution loss, significant shortages are expected in 2030, unless effective policies are implemented in the water sector.

Evidently, water supply depends on the amount rainfall which, in turn, is subject to climate change. Three climate change scenarios are considered, A2, A1B and B1. The A2 storyline projects slower economic growth and technological change than storylines A1 and B1. The A1 storyline and scenario family describes a future world of very rapid economic growth; a global population that peaks mid-century and declines thereafter; the rapid introduction of new and more efficient technologies; and a balance of fossil and non-fossil energy across all sources (A1B). The B1 storyline and scenario family describes a convergent world with a similar global population that peaks mid-century and declines thereafter; with rapid changes in economic structures toward a service and information economy and reductions in material intensity; and the introduction of clean and resource-efficient technologies.

Under A2, water shortages will be in the range of 19 million m³ to 52 million m³, corresponding to an economic growth of 2 and 7 percent, respectively. Under A1B, water

shortages will be somewhere between 24 million m³ and 58 million m³; and under B1, the shortages will range from 15 million m³ to 49 million m³. With an economic growth rate of 5.5 percent, the shortages are estimated to range from 36 million m³ to 45 million m³ (B1 and A1B respectively).

6.6 Ensuring the Sustainable Supply of Water: Policy Implications

The main aim of constructing water accounts, analyzing current and future trends of water use, and scrutinizing governance in the water sector is to ensure a sustainable water supply, both in the short and long term. According to Isnard and Barraqué (2010), sustainability in the water sector involves three main facets: (i) economic sustainability, which refers to the capacity of water services to recover their costs, not only of operation and maintenance, but also of long-term investments; (ii) environmental sustainability, which requires that water corresponds to defined safety norms, that the use for water of future generations is guaranteed, and that the quality and quantity of water resources is safeguarded; and (iii) ethical or social aspects of sustainability, which means that users are able and willing to pay for the water services received.

The main issue is whether the present situation is economically sustainable. In relation to revenues and expenses, the CWA is currently able to cover its operating costs. However, this is far from ensuring a sustainable water service in the long run because the revenue structure does not allow for the costs of investments. It does not answer questions on financing long-term water storage systems or resolving the issue of faulty meters and pipelines in a systematic manner. Funding for these types of projects usually comes from the central government budget, although the WRU (under the Ministry of Energy and Public Utilities) is responsible for water resources in Mauritius.

Water storage and drinking water distribution are treated separately, thereby separating the production of raw water from water services (for drinking water and sanitation). In order to transform raw water into drinking water, heavy investments are needed: to store water adequately and properly; to provide a 24/7 service; and to prevent high leakage, which, in turn, ensures adequate pressure in the distribution network and helps avoid contamination. In this respect, the price of water should, as far as possible, include the costs of treatment, distribution and the storage of water. Under the current tariff regime, however, the price of water for consumers includes only the cost of the treatment of raw water and the maintenance of the distribution network. The cost of repairing pipes has to be paid for from central government budgets.

It is clear that the high level of Non-Revenue Water is one of the major issues facing the water sector in Mauritius. Half of this Non-Revenue Water is due to leaking pipelines. Thus, adopting a policy to address the issue of Non-Revenue Water will save 110 million m³, which is sufficient to cater for the rising demand for water, as well as for the effects of climate change on precipitation up to the year 2030. Taking the Bagatelle Dam project as an example – estimated at MUR 1.7 billion (USD 47.9 million) for 25 million m³ of storage – and allowing for losses of 50 percent through Non-Revenue Water, we would need more than five such projects to generate 110 million m³, at a cost of roughly MUR 9 billion (USD 253.5 million). Water is supplied through a distribution network made up of some 4,175km of pipes, excluding house connections. More than 1,000km of this network are subject to

frequent leaks and bursts. Using figures for the amount disbursed for pipelines, and new estimates, it appears that the average cost per kilometer stands at MUR 13 million (USD 366,000). Repairing these faulty pipes will cost a minimum of MUR 13 billion (USD 366.2 million).

A major finding is that the demand for water is highly price inelastic in the short as well as the long run. Pricing policy therefore cannot be used to curb demand for water. However, it can be used to raise revenue in the water sector if the tariff is increased. Water tariffs, especially in the residential sector, may be restructured since household consumption forms the largest segment of total (treated) water demand.

Let us consider the cost of replacing 1,000km of pipe. If we allow a period of 30 years to recover these costs, they may amount to MUR 400 million (USD 11.3 million) a year, at current values. Thus the water sector has to cater for this additional amount on an annual basis. With a price elasticity of -0.12, and a current annual revenue of MUR 696.3 million (USD 19.6 million), a 73 percent rise in average price would be needed to increase revenue by MUR 400 million. This excludes the additional revenue that would be obtained through reducing the level of Non-Revenue Water. This proposition, however, is far more complex than it first appears. Currently, all households are charged a fixed fee of MUR 45 (USD 1.27) per month for up to 10m³ of water, irrespective of use. Therefore, up to 10 m³, the average price is MUR 4.5 (USD 0.13) per cubic meter. The cost for additional cubic meters starts at MUR eight (USD 0.23) and increases exponentially (in increments). Therefore, a household may find it cheaper to install a second meter and to pay another MUR 45 for an additional 10m³, rather than pay for any additional cubic meters of water used. There is, therefore, a need to review the tariff structure, with due consideration to low-income or vulnerable households.

Alongside the revenue generated by household water consumption, the non-residential sector, including the manufacturing, services and government sectors, brings in an annual revenue of about MUR 592 million (USD 16.7 million). Estimates of output elasticity, the marginal productivity of water, and price elasticity of water in the economic sectors can be used to work out a tariff structure to maximize revenue.

However, restructuring the tariffs to increase revenue will not be enough to ensure economic sustainability in the Mauritian water sector. Chapter 4 of this study has identified one important reason for this lack of economic sustainability; namely, the separation of the requirements for water resources and drinking water distribution. The main bodies responsible for these tasks – the WRU and the CWA, respectively – have distinct approaches to securing funding for their tasks. A more holistic view of the water sector seems to be needed. This issue has been examined in detail in Section 2, in the analysis of governance in the water sector.

6.7 The Institutional Setting of Water Sector Governance

Water sector governance has been defined as the system in place to oversee, plan, direct, monitor and enforce the transactions between the various water uses. Its task is therefore to determine rules and practices for decision-making in the water sector. In order to be able

to draw an accurate picture of water sector governance in Mauritius, an analytical framework has been developed to identify the distribution of tasks related to the various dimensions of water sector governance among the different water actors. As a result, it has been found that water sector governance in Mauritius is not vertically decentralized – in other words, all water actors operate at the national level of government and no regional or local actors are involved. This finding is interesting because it is a stark contrast to practically all other countries in the world, where water sector governance is usually vertically decentralized to a significant degree, allocating key responsibilities to regional and/or local actors. Even though the very small geographic size of Mauritius might explain centralized policymaking by actors at the national level, especially with regard to water resources, it is questionable whether the provision of drinking water, which is typically a local public service, should also be organized at the national level.

However, even though water governance is vertically centralized, it has been shown that there is a great deal of horizontal decentralization, meaning that a multitude of actors and government bodies intervene at the national level. The main actors are: the MEPU (with its parastatal bodies, the WRU, the CWA, and the WMA); the National Assembly; the Ministry of Agro Industry and Food Security, along with the Irrigation Authority; the Ministry of Environment and its Pollution Prevention and Control Division, the National Environmental Laboratory, the Law and Prosecution Division and the Environmental Police; the Ministry of Health and Quality of Life and its Environmental Health Unit; and the Water Advisory Council.⁵⁴ All of these ministries, ministry divisions and parastatals fulfill various tasks in water resource planning, development and management, drinking water services and wastewater services.

6.8 Water Sector Governance and (the Lack of) Sustainability

Given the likelihood of water scarcity, predicted by the climate change scenarios in Chapter 3, the extent to which sustainability is addressed in the governance of the water sector is particularly important. A sustainable water sector requires that it is economically viable, in the sense that it is able to recover the costs of services provided, including the costs for long-term investments; that the quality and quantity of water resources is safeguarded for future generations; and that tariffs are designed in such a way as to reflect the users' ability and willingness to pay.

As the findings of this study suggest, it is questionable whether Mauritius is prepared to face expected water scarcity in the future. There are existing plans to raise the capacity for water storage through the construction of new dams and reservoirs, but it is debatable whether this is an efficient approach given the very high rate of Non-Revenue Water (of between 50 and 55 percent). The CWA is currently addressing this particular issue by trying to reduce the leakage rate and commercial losses linked to defective water meters. It is, nevertheless, unclear how much time this will take.

⁵⁴ According to our respondents, the Water Advisory Council has not been operational until very recently.

The economic sustainability of water services provided in Mauritius is also in danger. Tariffs are very low – among the lowest in Africa – and currently barely cover operating costs. Since current costs (for example, for energy) are expected to rise in the future, the situation will probably deteriorate further. A change in government policy toward the elimination of government subsidies for long-term investments is putting additional pressure on water service finances.

As for social sustainability, social tariffs are offered to one-third of households, although, according to official government statistics, only one-tenth of these are really in need of such preferential tariffs. In addition, the current tariffs do not take into account the size of the household. This might have a regressive effect on large, low-income families who might have to pay a higher bill than families with fewer children and more financial means. Another problem lies in the very high levels of cross-subsidization from commercial to domestic users. The latter benefit *de facto* from tariffs that do not even cover the operating costs for the services provided. As a consequence, rather than providing financial support to those consumers in need, social tariff setting in Mauritius is a source of public wastage, further endangering the economic sustainability of the water sector. This is because consumers who could afford to pay tariffs that are closer to reflecting the full cost of providing water services are paying the social tariff which is too low to even cover operating costs – entailing a foregone opportunity to generate revenue.

In light of the urgent sustainability issues that the Mauritian water sector faces, the National Water Policy, as outlined in July 2014, seems to mark a turning point toward more sustainable water sector governance. It addresses imminent problems such as the need for full-cost recovery or integrated water resource management (Ministry of Energy and Public Utilities, 2014). However, this document was prepared by the last government and it remains to be seen whether the current government, elected in December 2014, has enough political will to commit itself to such an ambitious program. The perception among our respondents was that it was unlikely that this water policy would be implemented.

Furthermore, it appears that the MEPU is unaware of the sustainability issues in the Mauritian water sector. Our study suggests that one of the main reason for this might lie in weaknesses in governance. Several issues seem of particular importance and lead to a number of policy recommendations presented in the following section.

6.9 Policy Recommendations to Improve Water Sector Governance

Our study revealed several water governance issues. For one, responsibilities are unclearly delineated so that they often overlap. This makes it difficult for water actors to take firm decisions and act upon them. A policy recommendation would, therefore, be to review the responsibilities of the various water actors and delineate them properly. For instance, the WRU, which comes under the Ministry of Energy and Public Utilities, should be provided with a distinct legal framework, rather than being embedded in the CWA Act, which currently results in overlapping tasks and functions. To achieve this, a possible solution would be to develop a Water Act which would harmonize current legislation and allocate functions and responsibilities clearly among the various water actors.

This is closely related to the second recommendation. It would be highly desirable to provide key water actors, such as the CWA, the WMA and the WRU, with more autonomy. Our study shows that the CWA is well aware of the lack of economic sustainability for its drinking water services but it can do little to tackle the issue because the decision-making power for tariff setting lies with its line ministry, the MEPU. More independence for Mauritian water actors would also enable them to overcome the issue of time inconsistency – in other words, the fact that the government sacrifices necessary sustainable long-term considerations in order to gain short-term political support. This lack of strong political will has been pervasive in the Mauritian water sector over the last few decades.

The third obstacle to effective water governance, highlighted in this study, concerns the issue of transparency and of information sharing between the various water actors, which is hampered by the absence of indicators and objectives. As a policy recommendation, water actors should aim at developing such indicators. These could include (among others): the leakage rate, the rate of Non-Revenue Water, the number of unplanned interruptions of service, the ratio of employees to connections, the time needed to respond to consumer complaints, the renewal rate of the distribution network; as well as indicators related to the chemical and biological composition of the water. These indicators can be developed for the national level but should also be constructed for a lower geographical scale. Performance indicators could be developed for the various water reservoirs, for instance, and also for the six points of distribution that the CWA uses. All these indicators should be made publicly accessible on a website so that all water stakeholders, including users, can access the data. In France, for instance, the National Office for Water and Aquatic Environments (*Observatoire National de l'Eau et des Milieux Aquatiques*) has recently been created for the purpose of collecting and publishing data on all aspects of drinking and wastewater services.

This leads to the fourth and final policy recommendation on water sector governance. These regional performance indicators should then be used to introduce performance benchmarking for the various water services – for example, to compare the performance of different water resources, drinking water distribution points and wastewater treatment plants.⁵⁵ This would not only enhance the transparency of the water sector but also of decision-making processes, by providing a higher level of information to all water actors. Furthermore, it would lead to *benchmark competition*, a type of virtual competition which is known for its efficiency enhancing effects and which is particularly suited to monopolistic sectors such as the water sector. By comparing the performance of the various regional segments, each segment would have an incentive not to be the one with the lowest performance. This type of regulation is also known as 'sunshine regulation' since it sheds light on the (previously hidden) performance of a utility. This option is less costly than setting up a specific regulatory body. Creating a separate regulatory agency might be very difficult in light of strained public budgets and the Mauritian institutional context, which might not allow for sufficient independence of the regulator to be effective. In addition sunshine regulation is much easier to implement. Basically, it requires a certain amount of

⁵⁵ This could be done even though the points of distribution are partly interconnected.

data and a website to publish it. This type of regulation could help to improve levels of efficiency and performance in the water sector.

All in all, these measures would help Mauritius to be better prepared for current and future challenges to its water sector.

References

Isnard, L. And Barraqué, B. (2010). *Bibliographie commentée*. Deliverable 1 of the research project Eau&3E – La durabilité des services d'eau dans les grandes villes. Project funded by the French Research Agency (*Agence Nationale de la Recherche*).

Ministry of Energy and Public Utilities (2014). *National Water Policy*. Port Louis: Ministry of Energy and Public Utilities.

Annexes

Annex A: Water Legislation in Mauritius

Central Water Authority legislation:

Title of Act	Number	Year	Main features
Central Water Authority Act 1971 updated	Act 20/1971	1971	Creation and outline of the Act in the current version. Board composition decided by Minister (§7). Budget needs <i>ex ante</i> approval by Minister (§27). No liability for damages for impure water or insufficient / irregular water supply (§42).
Central Water Authority Act 1971	Act No. 20 of 1971	1971	Original CWA Act.
Central Water Authority (Amendment) Act 1975	Act No. 26 of 1975	1975	Change of Board composition. Definition of fines for tampering with water meters.
Central Water Authority (Amendment) Act 1982	Act No. 39 of 1982	1982	Change of Board composition.
Central Water Authority (Amendment) Act 1985	Act No. 4 of 1985	1985	Establishment of a Water Advisory Council with a Board, whose Chairman appointed by Minister, comprising CWA and several Ministries, namely Ministry of Finance; Energy and Internal Communications; Economic Planning and Development; Labor and Industrial Relations; and members with experience in agricultural, industrial, commercial, financial, scientific or administrative matters, appointed by the Minister.
Central Water Authority (Amendment) Act 1989	Act No. 31 of 1989	1989	Definition of fines for discharging polluted water.
Central Water Authority (Amendment) Act 1992	Act No. 4 of 1992	1992	Change of time span appointed members of Board may serve.
Central Water Authority (Amendment) Act 2000	Act No. 27 of 2000	2000	Possibility of concession contracts for the supply of water.
Central Water Authority (Amendment) Act 2005	Act No. 3 of 2005	2005	Defines fines for water offences (§3(a)).

Title of regulation	Number		Main features
Central Water Authority (Census of Water Rights) Regulations 2013	GN No. 106	2013	Census of water rights holders from various sectors to collect information on water sources, consumption and return flows.
Central Water Authority (Census of Water Rights) (Amendment) Regulations 2011	Notice No. 206 of 2011	2011	Not online.

Central Water Authority (Water Supply for Non-Domestic Purposes) Regulations 1992 - updated	GN 123/1992	1992	Metering of water and applicable tariffs.
Central Water Authority (Water Supply for Domestic Purposes) Regulations 1992 - updated	GN 122/1992	1992	Domestic water supply tariffs.
Central Water Authority (Irrigation) Regulations 1973 - updated	GN 5/1973	1973	Regulations concerning water for irrigation and corresponding tariffs.
Central Water Authority (Water Supply for Non-Domestic Purposes) (Amendment) Regulations 2008	GN No. 10 of 2008	2008	Regulations and fees for non-domestic water supply.
Central Water Authority (Water Supply for Domestic Purposes) (Amendment) Regulations 2008	GN No. 9 of 2008	2008	Regulations and fees for domestic water supply.
Central Water Authority (Water Supply for Non-Domestic Purposes) (Amendment) Regulations 2006	GN No. 175 of 2006	2006	Regulations and tariffs for non-domestic water supply.
Central Water Authority (Water Supply for Domestic Purposes) (Amendment) Regulations 2006	GN No. 174 of 2006	2006	Regulations and tariffs for domestic water supply including social considerations.
Central Water Authority (Water Supply for Non-Domestic Purposes) (Amendment) Regulations 2005	GN No. 12 of 2005	2005	Regulations and tariffs for non-domestic water supply.
Central Water Authority (Water Supply for Non-Domestic Purposes) (Amendment) Regulations 2003	GN No. 5 of 2004	2004	Regulations for non-domestic water supply. Single bill for water and wastewater.
Central Water Authority (Water Supply for Domestic Purposes) (Amendment) Regulations 2003	GN No. 4 of 2004	2004	Regulations for domestic water supply. Single bill for water and wastewater.
Central Water Authority (Irrigation) (Amendment) Regulations 2003	GN No. 81 of 2003	2003	Regulations for irrigation due to newly available water from Midlands Dam.

Central Water Authority (Water Supply for Domestic Purposes) (Amendment) Regulations 2002	GN No. 98 of 2002	2002	Regulations and revised tariffs for domestic water supply.
Central Water Authority (Water Supply for Non-Domestic Purposes) (Amendment) Regulations 2002	GN No. 97 of 2002	2002	Regulations and revised tariffs for non-domestic water supply.
Central Water Authority (Drought Period) (Repeal) Regulations 2000	GN No. 36 of 2000	2000	Repeal of drought regulations from 1999.
Central Water Authority (Water Supply for Non-Domestic Purposes) (Amendment) Regulations 2000	GN No. 15 of 2000	2000	Regulations and revised tariffs for non-domestic water supply.
Central Water Authority (Water Supply for Domestic Purposes) (Amendment) Regulations 2000	GN No. 14 of 2000	2000	Regulations and revised tariffs for domestic water supply.
Central Water Authority (Drought Period) Regulations 1999 (Repealed)	GN No. 70 of 1999	1999	Drought regulations prohibiting non-essential water use.
Central Water Authority (Water Supply for Non-Domestic Purposes) (Amendment) Regulations 1998	GN No. 114 of 1998	1998	Regulations and revised tariffs for non-domestic water supply.
Central Water Authority (Water Supply for Domestic Purposes) (Amendment) Regulations 1998	GN No. 113 of 1998	1998	Regulations and revised tariffs for domestic water supply.
Central Water Authority (Water Supply for Non-Domestic Purposes) (Amendment) Regulations 1998	GN No. 76 of 1998	1998	Regulations and revised tariffs for non-domestic water supply for use of water from Midlands Dam.
Central Water Authority (Water Supply for Non-Domestic Purposes)	GN No. 123 of 1992	1992	Regulations and revised tariffs for non-domestic water supply.
Central Water Authority (Water Supply for Domestic Purposes) Regulations 1992	GN No. 122 of 1992	1992	Regulations and revised tariffs for non-domestic water supply.

Central Water Authority (Irrigation) (Amendment) Regulations 1988	GN No. 27 of 1988	1988	Revised tariffs and rates for irrigation.
Central Water Authority Water Supply for Non-Domestic Purposes) (Amendment) Regulations 1988	GN No. 26 of 1988	1988	Regulations and revision of 1980 tariffs for non-domestic water supply.
Central Water Authority (Water Supply for Domestic Purposes) (Amendment) Regulations 1988	GN No. 25 of 1988	1988	Regulations and revision of 1980 tariffs for non-domestic water supply.
Central Water Authority (Designation of Catchment Areas) Regulations 1986	GN No. 44 of 1986	1986	Designation of catchment areas with maps.
Central Water Authority (Water Supply for Domestic Purposes) (Amendment No. 2) Regulations 1984	N No. 143 of 1984	1984	Amendment of 1980 regulations for domestic water supply.
Central Water Authority (Water Supply for Non-Domestic Purposes) (Amendment No.2) Regulations 1984	GN No. 142 of 1984	1984	Amendment of 1980 regulations for non-domestic water supply.
Central Water Authority (Water Supply for Non-Domestic Purposes) (Amendment) Regulations 1984	GN No. 11 of 1984	1984	Amendment of 1980 regulations and tariffs for non-domestic water supply.
Central Water Authority (Water Supply for Domestic Purposes) (Amendment) Regulations 1984	GN No. 10 of 1984	1984	Amendment of 1980 regulations and tariffs for non-domestic water supply.
Central Water Authority (Election of Employees) Regulations 1983	GN No. 11 of 1983	1983	Change of procedural rules for election of employees in the Board.
Central Water Authority (Water Supply for Non-Domestic Purposes) (Amendment) Regulations 1982	GN No. 304 of 1982	1982	Amendment of regulations and tariffs for non-domestic water supply.
Central Water Authority (Water Supply for Domestic Purposes) (Amendment) Regulations 1982	GN No. 303 of 1982	1982	Amendment of regulations and tariffs for domestic water supply.

Central Water Authority (Water Supply for Non-Domestic Purposes) (Amendment) Regulations 1981	GN No. 349 of 1981	1981	Amendment of regulations and tariffs for non-domestic water supply.
Central Water Authority (Water Supply for Domestic Purposes) (Amendment) Regulations 1981	GN No. 348 of 1981	1981	Amendment of regulations and tariffs for domestic water supply.
Central Water Authority (Census of Water Rights) (Amendment) Regulations 1981	GN No. 75 of 1981	1981	Regulations for carrying out a census of water right holders.
Central Water Authority (Water Supply for Non-Domestic Purposes) Regulations 1980	GN No. 271 of 1980	1980	Amendment of regulations and tariffs for non-domestic water supply.
Central Water Authority (Water Supply for Domestic Purposes) Regulations 1980	GN No. 270 of 1980	1980	Amendment of regulations and tariffs for domestic water supply.
Central Water Authority (Census of Existing Water Rights) Regulations 1980	GN No. 174 of 1980	1980	Regulations for carrying out a census of water right holders.
Central Water Authority (Irrigation) (Amendment) Regulations 1980	GN No. 173 of 1980	1980	Regulations for irrigation with rates and charges.
Central Water Authority (Water Supply for Domestic, Commercial and Industrial Purposes) (Amendment No. 4) Regulations 1979	GN No. 281 of 1979	1979	Amendment of regulations and tariffs for domestic, commercial and industrial water supply.
Central Water Authority (Water Supply for Domestic, Commercial and Industrial Purposes) (Amendment No. 3) Regulations 1979	GN No. 255 of 1979	1979	Amendment of regulations and tariffs for domestic, commercial and industrial water supply.
Central Water Authority (Water Supply for Domestic, Commercial and Industrial Purposes) (Amendment No. 2) Regulations 1979	GN No. 213 of 1979	1979	Amendment of regulations and tariffs for domestic, commercial and industrial water supply.

Central Water Authority (Water Supply for Domestic, Commercial and Industrial Purposes) (Amendment) Regulations 1979	GN No 167 of 1979	1979	Amendment of regulations and tariffs for domestic, commercial and industrial water supply.
Central Water Authority (Water for Domestic, Commercial and Industrial Purposes) (Amendment No. 2) Regulations 1974	GN No 163 of 1974	1974	Amendment of regulations and tariffs for domestic, commercial and industrial water supply.
Central Water Authority Supply for Domestic, Commercial and Industrial Purposes) (Amendment) Regulations 1974	GN No. 153 of 1974	1974	Amendment of regulations and tariffs for domestic, commercial and industrial water supply.
Central Water Authority (Water Supply for Domestic, Commercial and Industrial Purposes) Regulations 1974	GN No. 91 of 1974	1974	Amendment of regulations and tariffs for domestic, commercial and industrial water supply.
Central Water Authority (Water Supply for Domestic, Commercial and Industrial Purposes) (Amendment) Regulations 1974	GN No. 55 of 1974	1974	Amendment of regulations and tariffs for domestic, commercial and industrial water supply.
Central Water Authority (Vesting Day) Order 1973	GN No. 10 of 1973	1973	Rates and charges for irrigation.
Central Water Authority (Water Supply for Domestic Commercial and Industrial Purposes) Regulations	GN No. 6 of 1973	1973	Regulations for domestic commercial and industrial water supply.
Central Water Authority (Irrigation) Regulations 1973	GN No. 5 of 1973	1973	Regulations, rates and charges for irrigation.
Central Water Authority (Vesting Day) Order 1973	GN No. 4 of 1973	1973	Not important.
Central Water Authority (Water Supply for Domestic Purposes) Regulations 2011	GN No. 228 of 2011	2011	Incorrect document. Refers to Wastewater Management Authority Act.
Central Water Authority (Water Supply for Non-Domestic Purposes) Regulations 2011	GN No. 239 of 2011	2011	Incorrect document. Refers to Wastewater Management Authority Act.

Central Water Authority (Production of Drinks) (Fees and Other Charges) Regulations 2011	GN No. 241 of 2011	2011	Incorrect document. Refers to Wastewater Management Authority Act.
Central Water Authority (Irrigation) (Amendment) Regulations 2011	GN No. 241 of 2011	2011	Incorrect document. Refers to Wastewater Management Authority Act.

Ground water legislation:

Title of Act	Number	Year	Main features
The Ground Water Act 1969	Act 55/1969	1969	Creation of the Ground Water Act on the ownership, control and use of groundwater. Groundwater as public property. Definition of rules for licensing of groundwater abstraction and sanctions for failure of compliance with them.
The Ground Water Act 1969	Act No. 55 of 1969	1969	Same as Act 55/1969.
The Ground Water Act Regulations 1989	GN No. 68 of 1970	1970	Repeal of former regulations.
The Ground Water Act 1973	Act No. 6 of 1973	1973	CWA responsible for groundwater.
The Ground Water Act Regulations 1973	GN No. 74 of 1973	1973	Regulations, fees and charges for licenses for groundwater abstraction.
The Ground Water Act Regulations 1989	GN No. 74 of 1973	1973	Regulation of yearly license fees.
The Ground Water Act Regulations 1989	GN No. 124 of 1992	1992	Regulation of license fees for domestic, irrigation, and industrial groundwater abstraction.
The Ground Water Act Regulations 1989	GN No. 128 of 1996	1996	Regulations, fees and penalties relating to groundwater abstraction.
The Ground Water Act Regulations 1998	GN No. 115 of 1998	1998	Regulations and charges for use of groundwater for industrial purposes.
The Ground Water Act Regulations 1989	GN No. 5 of 1998	1998	Regulations and fees for groundwater abstraction.
The Ground Water Act Regulations 2002	GN No. 96 of 2002	2002	Regulations, fees and charges for licenses for groundwater abstraction.
The Ground Water Act Regulations 2006	GN No. 173 of 2006	2006	Regulations for licenses for groundwater abstraction.
The Ground Water Act Regulations 2011	GN No. 240 of 2011	2011	Incorrect document. Refers to Wastewater Management Authority Act.

Wastewater legislation:

Title of the Act	Number	year	Main features
The Waste Water Management Authority Act 2000	Act 39/2000	2000	Creation of WMA, tasks and rules in updated version. Board composition decided by Minister (\$8). Budget needs <i>ex ante</i> approval by Minister (\$24).
The Waste Water Management Authority (Amendment) Act 2000	Act No. 39 of 2000	2000	Original version of WMA Act.
The Waste Water (Fees) Regulations 2001	GN No. 105/2001	2001	Amendment of wastewater fees.
The Waste Water Regulations 2001	GN No. 105 of 2001	2001	Revision of wastewater fees for households and businesses.
The Waste Water Authority (Licensing of Effluent Carriers and Disposal of Effluent) Regulations 2001	GN No. 48 of 2001	2001	Regulations for the licensing of effluent carriers and the disposal of effluent.
The Waste Water Management Authority (Amendment) Act 2002	Act No. 42 of 2002	2002	Extension of transitory period for internal issues of WMA.
The Waste Water Regulations 2001	GN No. 10 of 2002	2002	Revision of wastewater fees.
The Waste Water Management Authority (Amendment) Act 2003	Act No. 33 of 2003	2003	Amendment of rules concerning banking cheques.
The Waste Water (Fees) (Amendment) Regulations 2003	GN No. 114 of 2003	2003	Revision of wastewater fees.
The Waste Water Management Authority (Amendment) Act 2004	Act No. 26 of 2004	2004	Prohibition on free disposal of effluent and wastewater.
The Waste Water (Standards for Discharge of Industrial Effluent into a Waste Water System) Regulations 2004	GN No. 182 of 2004	2004	Definition of standards for discharge of industrial effluent into a wastewater system
The Waste Water (Fees) (Amendment) Regulations 2004	GN No. 6 of 2004	2004	Revision of wastewater fees for business consumers.
The Waste Water (Registration of Waste Water Carriers & Disposal of Waste Water) Regulations 2006	GN No. 37 of 2006	2006	Regulation of wastewater carriers.

The Waste Water (Fees) (Amendment) Regulations 2008	GN No. 40 of 2008	2008	Revision of wastewater fees for different consumer groups.
The Waste Water (Fees) Amendment (No.2) Regulations 2011	GN No. 228 of 2011	2011	Regulation of wastewater fees.
Waste Water (Miscellaneous Waste Water Services) (Fees) Regulations 2012	GN No. 186 of 2012	2012	Regulation of applications for wastewater services and fees.

Surface water legislation:

Name of Act	Number	Year	Main features
Rivers and Canals Act 1863	Act 35/1863	1863	Creation of the Rivers and Canals Act on the ownership, control and use of groundwater. Rivers and canals are public property. Private parties may have a right.
Rivers and Canals Act 1968	Act No. 41 of 1968	1968	Procedural regulations related to documents on official meetings.

Annex B: Water Governance Survey



Survey on Water Governance in Mauritius⁵⁶

Survey Respondent

Name	
Title	
Organization	
Email	
Telephone	

ALL INFORMATION IS GOING TO BE TREATED ANONYMOUSLY.

Contact person

Please return the survey and any accompanying documents to ap@infragovernance.com. Dr Aleksandra Peeroo is Chief Consultant at InfraGovernance Consulting. For additional questions, do not hesitate to contact her by email or by phone: 5713 3422.

Background information

This survey is part of a research project on the Mauritian water sector funded by the Global Development Network, a public international organization. The project is entitled “Governance and Economic Accounting Issues in the Mauritian Water Sector: Toward Sustainable Management of a Natural Resource” and is carried out by Dr Aleksandra Peeroo (InfraGovernance Consulting) and Mr Riad Sultan (University of Mauritius).

The aim of this research project is to analyse the status quo of water resources through the establishment of water accounts and scenarios for future development in the light of climate change and to analyse the framework for water sector governance in order to understand whether Mauritius is, or will be, facing a water crisis.

This survey is a key step in providing a comprehensive and in-depth analysis of water governance in Mauritius, pinpointing substantial issues such as coordination, inclusion of stakeholders, and sustainability.

⁵⁶ The design of this survey draws extensively on the OECD Survey on Water Governance (2009-2010) and has been adapted to reflect the situation in Mauritius and address sustainability issues. The original OECD survey is available at <http://www.oecd.org/governance/regional-policy/44689618.pdf> (31.08.2015).

Objectives of the questionnaire

Decision-makers from different government ministries and agencies are targeted in this survey. Your responses will help us to answer the following questions:

- What coordination issues arise in water governance from the variety of water actors and stakeholders?
- What are the mechanisms in place to facilitate coordination?
- What are the main governance challenges?
- What role do sustainability considerations play in Mauritian water sector governance?

Some definitions

This survey uses the following terms:

- **Water Governance:** the system in place to oversee, plan, direct, monitor and enforce the transactions between the various water uses. It determines the rules and practices for decision-making about water policy and implementation and involves political, institutional and administrative processes.
 - **Multi-level Governance:** Different actors typically intervene in water governance, leading to a decentralised governance setting. Vertically, different levels of government might intervene in water governance, e.g. the national, the municipal / district council, and the village council level. Horizontally, several actors might intervene at the same level. For instance, at the national level, several ministries and public agencies / bodies are typically involved in water governance.
 - **Sustainability:** three facets of sustainability are important for the water sector, namely economic, environmental and social sustainability.
 - o **Economic sustainability:** refers to the capacity of water services to recover their costs, not only for the operation and maintenance of water services, but also for long-term investments.
 - o **Environmental sustainability:** requires that water corresponds to defined safety norms, that the use of water for future generations is guaranteed, and that the quality and quantity of water resources is safeguarded.
 - o **Social sustainability:** concerns users' ability and willingness to pay for the water services received.
-

Q1: Beyond the list of following ministries and bodies, are there any other actors responsible for water sector governance at the national level?

- Ministry of Energy and Public Utilities
- Central Water Authority
- Wastewater Management Authority
- Water Resource Unit
- Ministry of Environment, Sustainable Development, Disaster and Beach Management
- Ministry of Health and Quality of Life
- Irrigation Authority
- National Assembly

Yes No

If yes, please specify (names and functions):

Q2: How are national government roles and responsibilities in water governance defined?

Please check all answers that apply and specify if necessary:

By Constitution? Yes No

By Law? Yes No

If yes, please specify which law(s):

Ad hoc? Yes No

Other? Yes No

If yes, please specify:

Q3: Are there legislations on compulsory service delivery commitment?

Yes No

If yes, which one(s)?

Q4: Is the quality of drinking water monitored at the tap of households?

Yes No

If yes, by what actor and how often?

Q5: How are the actions of the different water actors at the national level coordinated?

<i>Existing coordination mechanism across governance actors at national level</i>	<i>Yes</i>	<i>No</i>	<i>Details (Name, examples etc.)</i>
Ministry of water			
Line ministry			
Central agency for water-related issues			
Ad hoc high-level structure (National Council...)			
Inter-ministerial body (Committee, commission...)			
Inter-agency program			
Coordination group of experts			
Inter-ministerial mechanism for addressing territorial water concerns			
Other (please specify)			
No specific coordination mechanism			

Q6: Are there efforts to specifically coordinate water and energy policies at national level?

Yes No

If yes, please specify:

Q7: Are there efforts to specifically coordinate water and agricultural policies at national level?

Yes No

If yes, please specify:

Q8: Are there efforts to specifically coordinate water, urban / regional planning at national level?

Yes No

If yes, please specify:

Q9: At the national level, what are the most frequent obstacles to effective coordination between various actors in charge of water sector governance?

Please tick the appropriate box (1 = not important, 2 = somewhat important, 3 = very important, N/A = not applicable) and give some examples:

<i>Obstacles to effective coordination at national level</i>	<i>1</i>	<i>2</i>	<i>3</i>	<i>N/A</i>	<i>Examples</i>
Overlapping, unclear, non-existing allocation of responsibilities					
Intensive competition between different ministries (political rivalries etc.)					
Interference of lobbies					
Absence of common information and frame of reference for policymakers					
Lack of high political commitment and leadership in water policy					
Lack of staff and time					
Lack of institutional incentives for cooperation (objectives, indicators...)					
Lack of technical capacities					
Difficult implementation of central government decisions at local and regional level					
Mismatch between ministerial funding and administrative responsibilities					
Absence of strategic planning and sequencing decisions					
Absence of monitoring and evaluation of the outcomes of national water policies					
Difficulties related to implementation / adaptation to recent reforms					
Contradiction between national organization and supranational recommendations					
Lack of citizens' concern on water policy					
Other (please specify)					

Q10: How frequently does your institution interact with other water actors?

Please check all that apply:

<i>Water actor</i>	<i>Daily</i>	<i>Weekly</i>	<i>Every second week</i>	<i>Monthly</i>	<i>Quarterly</i>	<i>Twice a year</i>	<i>Yearly</i>	<i>Never</i>
Ministry of Energy and Public Utilities								
Central Water Authority								
Wastewater Management Authority								
Water Resource Unit								
Ministry of Environment, Sustainable Development, Disaster and Beach Management								
Ministry of Health and Quality of Life								
Irrigation Authority								
National Assembly								

With what other water actors does your institution interact and in which frequency?

Q11: Are there any actors involved in water governance at subnational level?

Please check all that apply:

		<i>WATER RESOURCES</i>	<i>WATER SUPPLY</i>	<i>WASTE-WATER</i>
<i>Actors at subnational level</i>	<i>Municipalities</i>			
	<i>Districts</i>			
	<i>Villages</i>			
	<i>Inter-municipal / -district / -village bodies</i>			
	<i>Water specific bodies (e.g. elected Waterboards...)</i>			
	<i>River basin organizations</i>			
	<i>Other (specify)</i>			

Please specify for any checked box (role in water sector governance):

Q12: Beyond official actors in water sector governance, are some Water Users' Associations involved?

Yes No

If no, please go directly to Q15. If yes, please answer Q13 and Q14.

Q13: Please specify which Water Users' Associations are involved in water sector governance (name, website, contact details)?

Q14: How do these groups participate in water sector governance?

Q15: What are the main governance challenges in the water sector?

Please tick the appropriate box (1 = not important, 2 = somewhat important, 3 = very important, N/A = not applicable)

<i>Challenges</i>	<i>1</i>	<i>2</i>	<i>3</i>	<i>N/A</i>	<i>Examples</i>
<i>Mismatch between hydrological and administrative boundaries</i>					
<i>Allocation of water resources across uses (domestic, industrial, agriculture)</i>					
<i>Resource stress</i>					
<i>Subnational governments' capacity to design / implement water policies</i>					
<i>Tariffication</i>					
<i>Cost recovery</i>					
<i>Investment needs in infrastructure</i>					
<i>Insufficient independence / powers of your institution</i>					
<i>Lack of capacity (Human Capital)</i>					
<i>Absence of National Water Policy (for entire water cycle)</i>					
<i>Environmental norms</i>					
<i>Public safety</i>					
<i>Service quality standards</i>					
<i>Limited citizen participation</i>					
<i>Horizontal coordination across ministries / government bodies</i>					
<i>Vertical coordination between different levels of government</i>					
<i>Quality / quantity of information</i>					
<i>Managing the specificity of rural areas</i>					

<i>Challenges</i>	<i>1</i>	<i>2</i>	<i>3</i>	<i>N/A</i>	<i>Examples</i>
<i>Managing the specificity of urban areas</i>					
<i>Managing the specificity of mountain areas</i>					
<i>Managing the specificity of coastal areas</i>					
<i>Lack of political will</i>					
<i>Limiting the influence of interest groups</i>					
<i>Climate change (droughts, changing rainfall patterns, torrential rains...)</i>					
<i>Economic sustainability</i>					
<i>Environmental sustainability</i>					
<i>Social sustainability</i>					
<i>Other</i>					

Q16: Has Mauritius recently experienced innovative practices in water governance or intends to do so in the near future (new design of water policies, new legislative or regulatory framework, coordination reforms, innovative delivery of water services, e.g. desalination, recycling used water...)?

Yes No

If yes, please specify:

Q17: Is there anything you would like to add?

Thank you for having taken the time to answer this questionnaire. Your effort is very much appreciated.